

SERRATURE PER PORTE BASCULANTI DA GARAGE

LOCKS FOR OVERHEAD GARAGE DOORS

SERRURES POUR PORTES DE GARAGE BASCULANTES

CERRADURAS PARA PUERTA DE GARAJE SUPERIOR



Vasta gamma di serrature fino a 6 punti di chiusura a cilindro tondo, a profilo europeo e a doppia mappa

Numerose lunghezze di cilindro disponibile per ogni tipo di spessore della porta

Possibilità di personalizzare l'attacco dell'asta al catenaccio
possibilità di avere varie finiture dell'involucro serratura, anche a richiesta del cliente

Serrature con sistemi anti effrazione non convenzionali brevettati

Disponibilità di kit di rinforzo supplementari e vasta gamma accessori

Placche di protezione esterne anti-effrazione

Serrature ottimizzate per funzione di sblocco motore

Wide range of locks up to 6 closing points with round, european profile and double bit cylinders

Several cylinder lengths available for each type of door thickness

Customization of the rod junction on the bolt

Possibility of different finishes, also on customer's request

Locks with patented unconventional anti-theft systems

Additional reinforcement set and wide range of accessories

Security plates

Special locks for motor release

SERRATURE MADE IN ITALY



prefer.eu



Garages
Garages
Garages
Garaje



Large gamme de serrures de 1 à 6 points de fermeture et cylindres rond, à profil européen ou à double panneton

Gamme complète de cylindres pour chaque épaisseur de porte

Possibilité de personnaliser la fixation de la tringle au pêne

Sur demande, nous pouvons vous fournir le boîtier de fermeture avec différentes finitions

Les serrures peuvent être équipées de systèmes anti-effraction brevetés

Des kits de renfort supplémentaires et une large gamme d'accessoires sont disponibles

Plaques de protection extérieures anti-perçage

Serrures spéciales pour déverrouillage du moteur

Amplia gama de cerraduras hasta 6 posiciones de cierre con cilindros redondos, perfil europeo y doble paletón

Varias longitudes de cilindro disponibles para cada tipo de espesor de puerta

Personalización de la barra de ataque al cerrojo

Varios acabados de la cerradura, también bajo demanda del cliente

Cerraduras con sistemas antirrobo no convencionales patentados

Kits de refuerzo adicionales y amplia gama de accesorios

Placas de seguridad

Cerraduras especiales para desbloqueo del motor



SERRATURE PER PORTE BASCULANTI DA GARAGE

LOCKS FOR OVERHEAD GARAGE DOOR

SERRURES POUR PORTES DE GARAGE BASCULANTES

CERRADURAS PARA PUERTA DE GARAJE SUPERIOR



INDEX



W511	97
B511	97
W551	98
B551	98
W719	99
B719	99



B730	100
B731	101



W5E1	102
B5E1	102



W810	103
W811	103
6810	103
6811	104
6820	104
6842	105

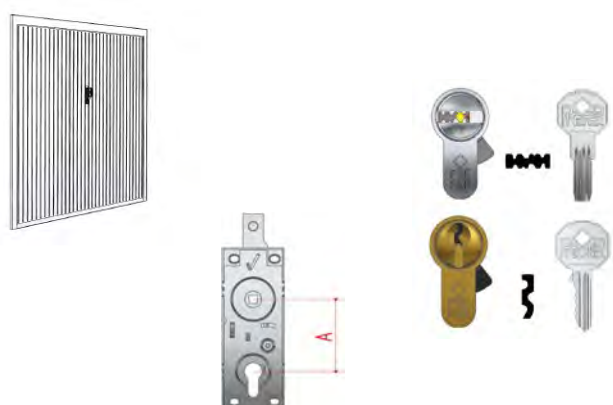

A = 70mm

W561	107
B561	107
W5B1	107
B5B1	107
W5A1	108
B5A1	108
W5D1	108
B5D1	108
W581	109
B581	109



SERRATURE PER PORTE BASCULANTI DA GARAGE

LOCKS FOR OVERHEAD GARAGE DOOR

SERRURES POUR PORTES DE GARAGE BASCULANTES

CERRADURAS PARA PUERTA DE GARAJE SUPERIOR



INDEX



A = 70mm



	☰
W598 110
6598 110
W599 110
6599 110
W562 111
6562 111
W563 111
6563 111
W574 112
6574 112
W584 112
6584 112



A = 60mm



	☰
65C1 113
W564 114
6564 114
W565 114
6565 114
W566 115
6566 115
W567 115
6567 115
65B2 116
W568 117
6568 117
W569 117
6569 117
W596 118
6596 118
W597 119
6597 119



SERRATURE PER PORTE BASCULANTI DA GARAGE

LOCKS FOR OVERHEAD GARAGE DOOR

SERRURES POUR PORTES DE GARAGE BASCULANTES

CERRADURAS PARA PUERTA DE GARAJE SUPERIOR



INDEX

		WE0S	120
		6A0N	120
		WLAS	121
		WMAS	121
		6KA0	122
		6HA0	122

		8651	123
		8652	124
		8653	124

		BSP3	125
		BSK1	125

		KBT1.0000.0000	127
		KBT2.SER1.0000	127
		KBT2.LUC1.0000	127
		KBT3.SER1.LUC1	127
		KBP1.0000.0000	128
		KBP2.SER2.0000	128
		KBP2.LUC1.0000	128
		KBP3.SER2.0000	128
		KW574	129
		0470	129
		BSK2	129
		0713	130
		K8653	130

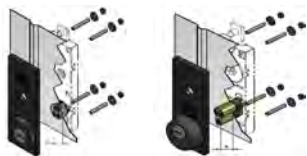

PLACCHE ESTERNE ANTIEFFRAZIONE

SECURITY PLATES

PLAQUES DE SECURITÉ

PLACAS DE SEGURIDAD

0479

.....



131

0478

.....

131



DISPOSITIVI DI PROTEZIONE - SICUREZZA

SECURITY DEVICES

DISPOSITIVES DE SECURITÉ

DISPOSITIVOS DE SEGURIDAD

0483

.....



132

0469

.....

132



CAVALLOTTI

MOUNTING U-BOLTS

PLAQUES DE FIXATION

PLACAS DE FIJACION

0458

.....



133

0459

.....

133



MANIGLIE E PLACCHE

HANDLES AND PLATES

POIGNÉES ET PLAQUES

MANIJAS Y PLACAS

0432

.....



134

0433

.....

134

0436

.....

134

0434

.....

135

0456

.....

135

0435

.....

135



SERRATURE PER PORTE BASCULANTI - CILINDRO TONDO

LOCKS FOR OVERHEAD GARAGE DOORS - ROUND CYLINDER

SERRURES POUR PORTES DE GARAGE BASCULANTES - CYLINDRE ROND

CERRADURAS PARA PUERTA DE GARAJE SUPERIOR - CILINDRO REDONDO



W

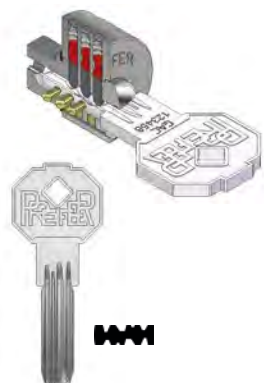

Chiave di sicurezza

Max 6 perni di cifratura:
4 perni in acciaio inox
2 perni passivi in ottone

Max. 3 contoperni a doppio fungo anti grimaldello carbonitrurati e nichelati e 1 contoperno antibumping

Finitura sabbata nichelato opaco

Combinazioni max W511: 1090
W551: 4410

Brocchia asimmetrica: apertura solo da esterno

Security key

Max 6 bitting pins:
4 stainless steel pins
2 passive brass pins

Max 3 double mushroom anti-picking carbonitrided and nickel-plated counterpins and 1 anti-bumping counter pin

Matt nickel sandblasted finish

Max combinations W511: 1090
W551: 4410

Asymmetrical broach: opening only from outside

Clé de sécurité

Max 6 goupilles :
4 goupilles en acier inoxydable
2 goupilles passives en laiton

Max 3 contre-goupilles anti-picking carbonitrurées et nickelées double champignon et 1 contre-goupille anti-bumping

Finition sablée nickel mat

Combinaisons max: W511: 1090
W551: 4410

Broche asymétrique: ouverture uniquement de l'extérieur

Llave de seguridad

Max 6 pitones:
4 pitones de acero inoxidable
2 pitones de latón pasivos

Max 3 contrapitones doble seta anti-picking carbonitrurados y niquelados y 1 contrapiton antibumping

Acabado arenado níquel mate

Combinaciones máximas: W511: 1090
W551: 4410

Brocha asimétrico: apertura solo desde el exterior

B

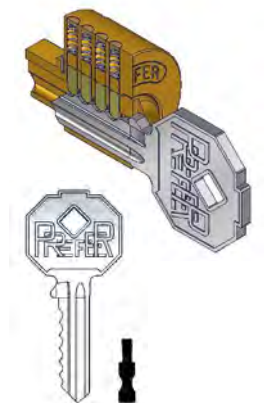

3/4 perni di cifratura in ottone

Finitura ottone naturale

Combinazioni max : 400

Apertura possibile sia da interno che esterno

Brocchia simmetrica

3/4 brass bitting pins

Natural brass finish

Max combinations : 400

Operating both from inside and outside

Symmetrical broach

3/4 coupilles en laiton

Fini laiton naturel

Combinaisons max: 400

Fonctionnement à la fois de l'intérieur et de l'extérieur

Broche symétrique

3/4 pitones de latón

Acabado en latón natural

Combinaciones máximas: 400

Apertura tanto desde el interior como desde el exterior

Brocha simétrica



SENZA MANIGLIA

SERRATURA PER PORTE BASCULANTI - CILINDRO TONDO SENZA MANIGLIA

LOCKS FOR OVERHEAD GARAGE DOORS - ROUND CYLINDER WITHOUT HANDLE

SERRURES POUR PORTES DE GARAGE BASCULANTES - CYLINDRE ROND SANS POIGNÉE

CERRADURAS PARA PUERTA DE GARAJE SUPERIOR - CILINDRO REDONDO SIN MANIJA

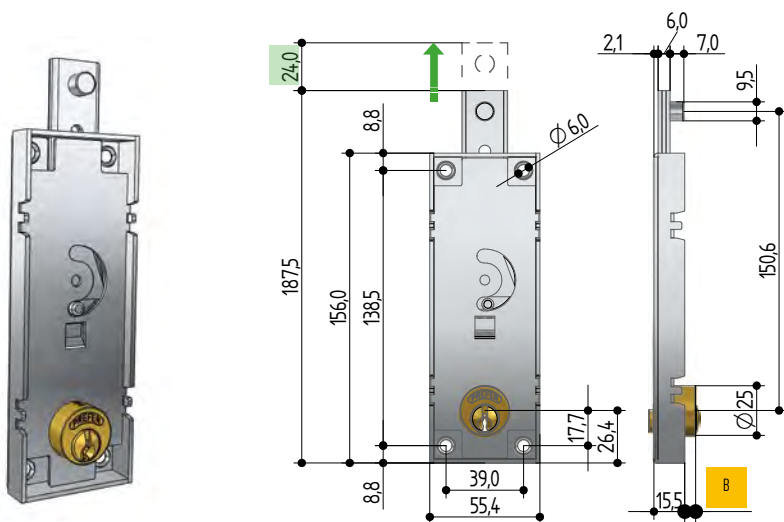

S511



codice code código														B mm					MIN ORD
1	2	3	4	5	6	7	8	9	10	11	12	13	14						
W	5	1	1	•	0	0	2	0	•	0	0	0	0	5,5	S810.0020	7300.1B00	40	1	10
W	5	1	1	•	0	0	2	2	•	0	0	0	0	9,3	S810.0022	7300.1A00	40	1	10

! Apertura solo dall'esterno

Outside opening only

Ouverture uniquement de l'extérieur

Apertura solo desde el exterior



B511



codice code código														B mm				MIN ORD	
1	2	3	4	5	6	7	8	9	10	11	12	13	14						
B	5	1	1	•	0	0	1	0	•	0	2	0	0	5,5	6810.0000	7100.1400	40	1	10
B	5	1	1	•	0	0	1	2	•	0	2	0	0	9,0	6810.0002	7100.1500	40	1	10
B	5	1	1	•	0	0	1	4	•	0	2	0	0	12,5	6810.0004	7100.1500	40	1	1
B	5	1	1	•	0	0	1	6	•	0	2	0	0	21,5	6810.0006	7201.1600	40	1	1
B	5	1	1	•	0	0	1	8	•	0	2	0	0	25,8	6810.0008	7201.1700	40	1	1
B	5	1	1	•	0	0	1	A	•	0	2	0	0	34,1	6810.000A	7101.1500	40	1	1

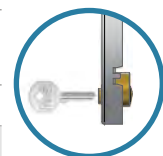



CLASSICA A CILINDRO

SERRATURA PER PORTE BASCULANTI - CILINDRO TONDO

LOCKS FOR OVERHEAD GARAGE DOORS - ROUND CYLINDER

SERRURES POUR PORTES DE GARAGE BASCULANTES - CYLINDRE ROND

CERRADURAS PARA PUERTA DE GARAJE SUPERIOR - CILINDRO REDONDO

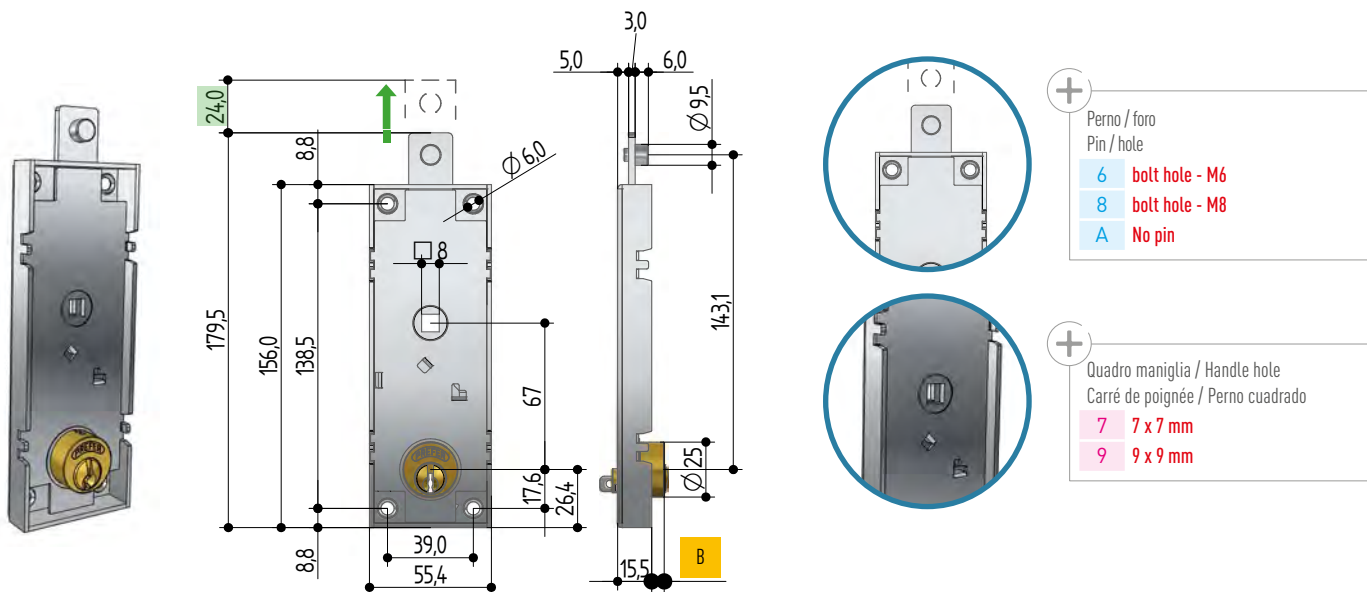

W551



codice code código														B mm					
1	2	3	4	5	6	7	8	9	10	11	12	13	14						
W	5	5	1	•	0	0	2	0	•	0	0	0	0	5,5	W811.0020	7300.2B00	40	1	10
W	5	5	1	•	0	0	2	2	•	0	0	0	0	9,3	W811.0022	7300.2A00	40	1	10

B551



codice code código														B mm					
1	2	3	4	5	6	7	8	9	10	11	12	13	14						
B	5	5	1	•	0	8	1	0	•	0	2	0	0	5,5	6811.0000	7100.1300	40	1	10
B	5	5	1	•	0	8	1	2	•	0	2	0	0	9,0	6811.0002	7100.1300	40	1	10
B	5	5	1	•	0	8	1	4	•	0	2	0	0	12,5	6811.0004	7100.1300	40	1	1
B	5	5	1	•	0	8	1	C	•	0	2	0	0	25	6820.000C	7100.1300	40	1	1
B	5	5	1	•	0	8	1	D	•	0	2	0	0	30	6820.000D	7100.1300	40	1	1
B	5	5	1	•	0	8	1	E	•	0	2	0	0	35	6820.000E	7100.1300	40	1	1
B	5	5	1	•	0	8	1	F	•	0	2	0	0	40	6820.000F	7100.1300	40	1	10
B	5	5	1	•	0	8	1	G	•	0	2	0	0	45	6820.000G	7100.1300	40	1	10
B	5	5	1	•	0	8	1	H	•	0	2	0	0	50	6820.000H	7100.1300	40	1	1
B	5	5	1	•	0	8	1	I	•	0	2	0	0	55	6820.000I	7100.1300	40	1	1
B	5	5	1	•	0	8	1	L	•	0	2	0	0	60	6820.000L	7100.1300	40	1	1
B	5	5	1	•	0	8	1	M	•	0	2	0	0	65	6820.000M	7100.1300	40	1	1
B	5	5	1	•	0	8	1	R	•	0	2	0	0	70	6820.000R	7100.1300	40	1	1
B	5	5	1	•	0	8	1	N	•	0	2	0	0	80	6820.000N	7100.1300	40	1	1
B	5	5	1	•	0	8	1	P	•	0	2	0	0	90	6820.000P	7100.1300	40	1	1



KIT A CILINDRO

SERRATURA PER PORTE BASCULANTI - CILINDRO TONDO

LOCKS FOR OVERHEAD GARAGE DOORS - ROUND CYLINDER

SERRURES POUR PORTES DE GARAGE BASCULANTES - CYLINDRE ROND

CERRADURAS PARA PUERTA DE GARAJE SUPERIOR - CILINDRO REDONDO

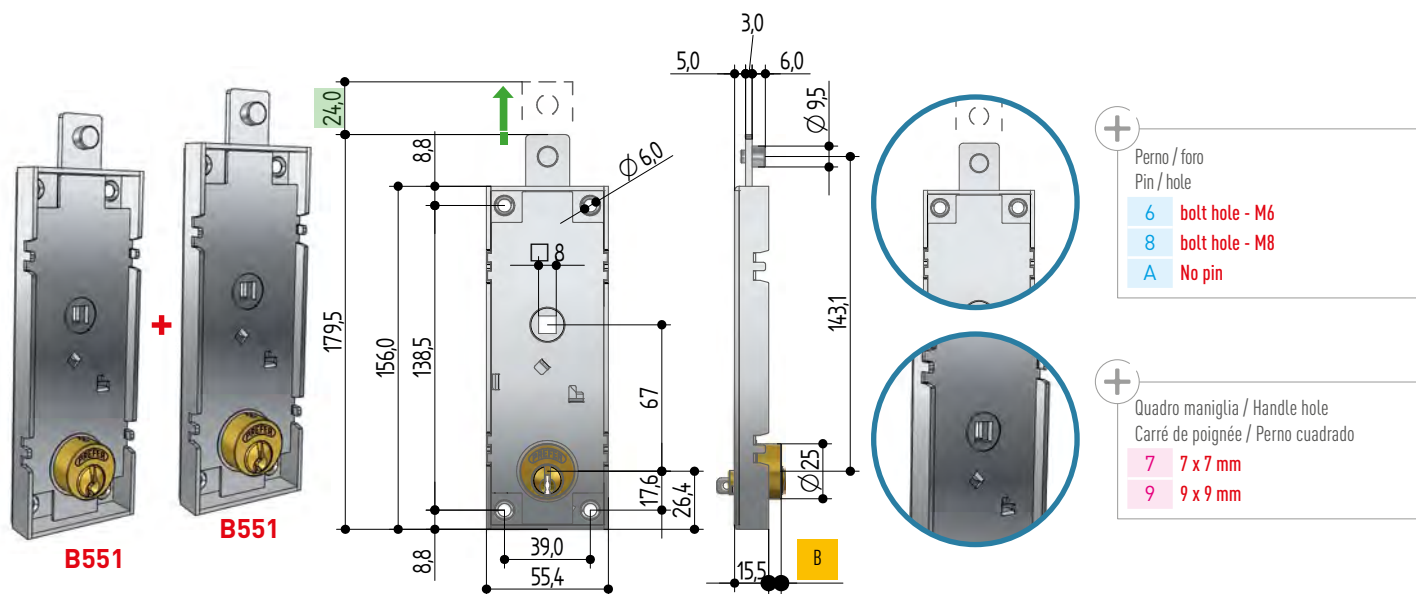

W719



codice code código														B mm	PREFER	3	MIN	ORD	
1	2	3	4	5	6	7	8	9	10	11	12	13	14						
W	7	1	9	•	0	8	2	0	•	0	5	0	0	5,5	W811.0020	7300.2A00	20	1	10
W	7	1	9	•	0	8	2	2	•	0	5	0	0	9,3	W811.0022	7300.2A00	20	1	10

B719



codice code código														B mm	PREFER	3	MIN	ORD	
1	2	3	4	5	6	7	8	9	10	11	12	13	14						
B	7	1	9	•	0	8	1	0	•	0	2	0	0	5,5	6811.0000	7100.1300	20	1	10
B	7	1	9	•	0	8	1	2	•	0	2	0	0	9,0	6811.0002	7100.1300	20	1	1
B	7	1	9	•	0	8	1	4	•	0	2	0	0	12,5	6811.0004	7100.1300	20	1	1
B	7	1	9	•	0	8	1	C	•	0	2	0	0	25	6820.000C	7100.1300	20	1	1
B	7	1	9	•	0	8	1	D	•	0	2	0	0	30	6820.000D	7100.1300	20	1	1
B	7	1	9	•	0	8	1	E	•	0	2	0	0	35	6820.000E	7100.1300	20	1	1
B	7	1	9	•	0	8	1	F	•	0	2	0	0	40	6820.000F	7100.1300	20	1	1
B	7	1	9	•	0	8	1	G	•	0	2	0	0	45	6820.000G	7100.1300	20	1	1
B	7	1	9	•	0	8	1	H	•	0	2	0	0	50	6820.000H	7100.1300	20	1	1
B	7	1	9	•	0	8	1	I	•	0	2	0	0	55	6820.000I	7100.1300	20	1	1
B	7	1	9	•	0	8	1	L	•	0	2	0	0	60	6820.000L	7100.1300	20	1	1
B	7	1	9	•	0	8	1	M	•	0	2	0	0	65	6820.000M	7100.1300	20	1	1
B	7	1	9	•	0	8	1	R	•	0	2	0	0	70	6820.000R	7100.1300	20	1	1
B	7	1	9	•	0	8	1	N	•	0	2	0	0	80	6820.000N	7100.1300	20	1	1
B	7	1	9	•	0	8	1	P	•	0	2	0	0	90	6820.000P	7100.1300	20	1	1



KIT PORTINA

SERRATURA PER PORTE BASCULANTI E PORTINA TRANSITO - CILINDRO TONDO



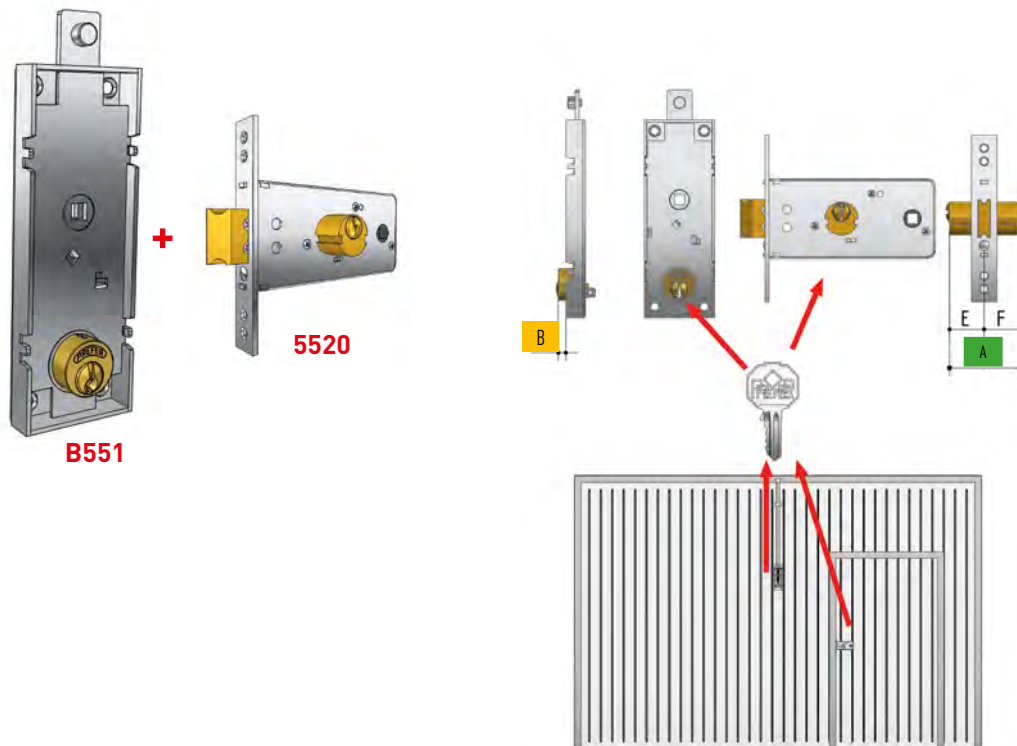

LOCKS FOR OVERHEAD GARAGE DOORS AND TRANSIT DOOR - ROUND CYLINDER

SERRURES POUR PORTES DE GARAGE BASCULANTES ET PORTE DE TRANSIT- CYLINDRE ROND

CERRADURAS PARA PUERTA DE GARAJE Y PUERTA DE TRÁNSITO- CILINDRO REDONDO



A mm=

codice code código														B mm	A mm				
1	2	3	4	5	6	7	8	9	10	11	12	13	14						
B	7	3	0	•	*	8	1	**	•	0	2	0	0	**	*	7100.1300	20	1	1
56 E+F(28+28)					0			2						9,0					
63 E+F (28 + 35)					1			4						12,5					
75 E+F (28+47)					2			C						25					
85 E+F (38 + 47)					8			D						30					
					8			E						35					
					8			F						40					
					8			G						45					
					8			H						50					
					8			I						55					
					8			L						60					
					8			M						65					
					8			R						70					
					8			N						80					
					8			P						90					



KIT DOPPIO PORTINA

SERRATURA PER PORTE BASCULANTI E PORTINA TRANSITO - CILINDRO TONDO

LOCKS FOR OVERHEAD GARAGE DOORS AND TRANSIT DOOR - ROUND CYLINDER



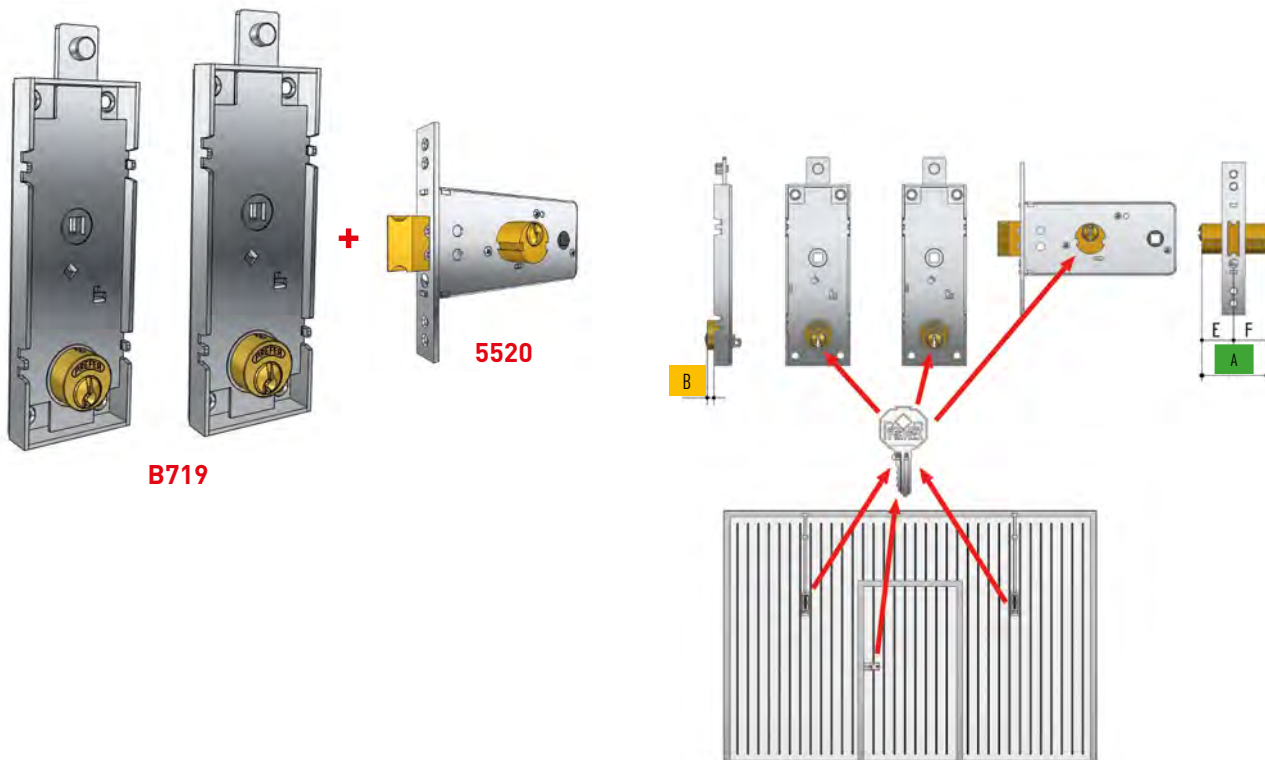

SERRURES POUR PORTES DE GARAGE BASCULANTES ET PORTE DE TRANSIT- CYLINDRE ROND

CERRADURAS PARA PUERTA DE GARAJE Y PUERTA DE TRÁNSITO- CILINDRO REDONDO



B731

A mm=

codice code código														B mm	A mm				
1	2	3	4	5	6	7	8	9	10	11	12	13	14						
B	7	3	1	•	*	8	1	**	•	0	2	0	0	**	*	7100.1300	10	1	1
56 E+F(28+28)					0				2					9,0					
63 E+F (28 + 35)					1				4					12,5					
75 E+F (28+47)					2				C					25					
85 E+F (38 + 47)					8				D					30					
					8				E					35					
					8				F					40					
					8				G					45					
					8				H					50					
					8				I					55					
					8				L					60					
					8				M					65					
					8				R					70					
					8				N					80					
					8				P					90					



BI-STABILE A CILINDRO



SERRATURA A CILINDRO TONDO BISTABILE PER PORTE BASCULANTI - CILINDRO TONDO

RE-ARMLESS LOCK FOR OVERHEAD GARAGE DOORS - ROUND CYLINDER

SERRURE BISTABLE POUR PORTES DE GARAGE BASCULANTES - CYLINDRE ROND

CERRADURA BISTABLE PARA PUERTAS DE GARAJE SUPERIOR - CILINDRO REDONDO



FUNZIONE BI-STABILE (serratura senza riarmo automatico)
Durante l'utilizzo ordinario la serratura può essere continuamente aperta e chiusa utilizzando solo la maniglia : non si blocca automaticamente in posizione di chiusura (come le comuni serrature da basculante) , per farlo occorre utilizzare la chiave.

RE-ARMLESS FUNCTION
During ordinary use the lock can be continuously opened and closed using only the handle : it does not automatically lock in the closing position (like the common locks for overhead doors) to do so you need to use the key.

FONCTION SANS RÉARMEMENT AUTOMATIQUE
Lors d'une utilisation ordinaire, la serrure peut être ouverte et fermée en continu en utilisant uniquement la poignée: elle ne se verrouille pas automatiquement en position de fermeture (comme les serrures communes pour les portes basculantes) pour ce faire, vous devez utiliser la clé.

FUNCIÓN SIN REARME AUTOMÁTICO
Durante el uso ordinario, la cerradura sigue abriéndose y cerrándose solo con la manija : no se bloquea automáticamente en la posición de cierre (como las cerraduras comunes para puertas de garaje) para hacerlo, debe usar la llave.

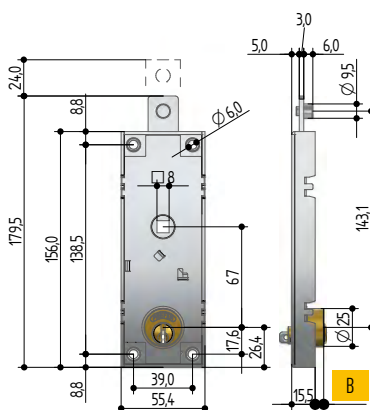

+ Perno / foro
Pin / hole

- 6 bolt hole - M6
- 8 bolt hole - M8
- A No pin

+ Quadro maniglia / Handle hole
Carré de poignée / Perno cuadrado

- 7 7 x 7 mm
- 9 9 x 9 mm

W5E1



codice code código														B mm					
1	2	3	4	5	6	7	8	9	10	11	12	13	14						
W	5	E	1	•	0	8	2	0	•	0	0	0	0	5,5	W811.0020	7300.2A00	40	1	10
W	5	E	1	•	0	8	2	2	•	0	0	0	0	9,3	W811.0022	7300.2A00	40	1	10



B5E1



codice code código														B mm					
1	2	3	4	5	6	7	8	9	10	11	12	13	14						
B	5	E	1	•	0	8	1	0	•	0	2	0	0	5,5	6811.0000	7100.1300	40	1	10
B	5	E	1	•	0	8	1	2	•	0	2	0	0	9,0	6811.0002	7100.1300	40	1	10
B	5	E	1	•	0	8	1	4	•	0	2	0	0	12,5	6811.0004	7100.1300	40	1	1
B	5	E	1	•	0	8	1	C	•	0	2	0	0	25	6820.000C	7100.1300	40	1	1
B	5	E	1	•	0	8	1	D	•	0	2	0	0	30	6820.000D	7100.1300	40	1	1
B	5	E	1	•	0	8	1	E	•	0	2	0	0	35	6820.000E	7100.1300	40	1	1
B	5	E	1	•	0	8	1	F	•	0	2	0	0	40	6820.000F	7100.1300	40	1	10
B	5	E	1	•	0	8	1	G	•	0	2	0	0	45	6820.000G	7100.1300	40	1	10
B	5	E	1	•	0	8	1	H	•	0	2	0	0	50	6820.000H	7100.1300	40	1	1
B	5	E	1	•	0	8	1	I	•	0	2	0	0	55	6820.000I	7100.1300	40	1	1
B	5	E	1	•	0	8	1	L	•	0	2	0	0	60	6820.000L	7100.1300	40	1	1
B	5	E	1	•	0	8	1	M	•	0	2	0	0	65	6820.000M	7100.1300	40	1	1
B	5	E	1	•	0	8	1	R	•	0	2	0	0	70	6820.000R	7100.1300	40	1	1
B	5	E	1	•	0	8	1	N	•	0	2	0	0	80	6820.000N	7100.1300	40	1	1
B	5	E	1	•	0	8	1	P	•	0	2	0	0	90	6820.000P	7100.1300	40	1	1





CILINDRI DI RICAMBIO



SPARE CYLINDERS

CYLINDRES DÉTACHÉES

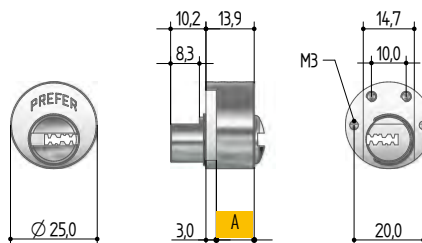
CILINDROS DE REPUESTO



W810

codice code código														A mm		per articolo for code			MIN ORD
1	2	3	4	5	6	7	8	9	10	11	12	13	14						
W	8	1	0	•	0	0	2	0	•	0	0	0	0	10,9	7300.2B00	W511	500	20	20
W	8	1	0	•	0	0	2	2	•	0	0	0	0	14,7	7300.2B00	W511	500	20	20

! Apertura solo dall'esterno



Outside opening only

Ouverture uniquement de l'extérieur

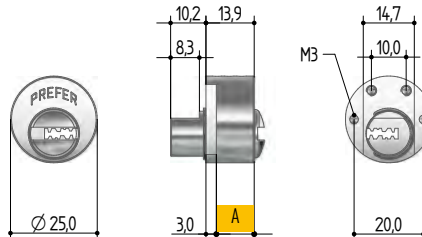
Apertura solo desde el exterior



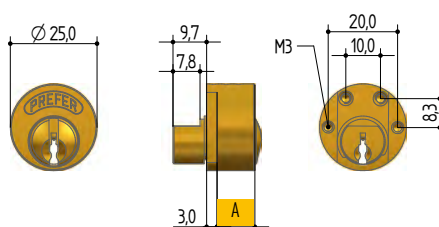

W811

codice code código														A mm		per articolo for code			MIN ORD
1	2	3	4	5	6	7	8	9	10	11	12	13	14						
W	8	1	1	•	0	0	2	2	•	0	0	0	0	14,7	7300.2A00	W551	200	20	20



6810

codice code código														A mm		per articolo for code			MIN ORD
1	2	3	4	5	6	7	8	9	10	11	12	13	14						
6	8	1	0	•	0	0	0	0	•	0	2	0	0	10,9	7100.1400	B511	200	20	20
6	8	1	0	•	0	0	0	2	•	0	2	0	0	14,4	7100.1500	B511	200	20	20
6	8	1	0	•	0	0	0	4	•	0	2	0	0	17,9	7100.1500	B511	200	20	20
6	8	1	0	•	0	0	0	6	•	0	2	0	0	26,9	7201.1600	B511	200	20	20
6	8	1	0	•	0	0	0	8	•	0	2	0	0	31,2	7201.1700	B511	200	20	20
6	8	1	0	•	0	0	0	A	•	0	2	0	0	39,5	7101.1500	B511	200	20	20



CILINDRI DI RICAMBIO



SPARE CYLINDERS

CYLINDRES DÉTACHÉES

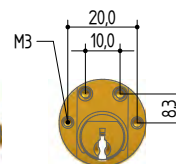
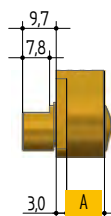
CILINDROS DE REPUESTO



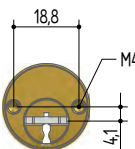
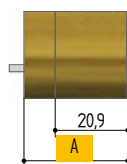

6811

codice code código														A mm		per articolo for code			MIN ORD
1	2	3	4	5	6	7	8	9	10	11	12	13	14						
6	8	1	1	•	0	0	0	0	•	0	2	0	0	10,9	7100.1300	B551	200	20	20
6	8	1	1	•	0	0	0	2	•	0	2	0	0	14,4	7100.1300	B551	200	20	20
6	8	1	1	•	0	0	0	4	•	0	2	0	0	17,9	7100.1300	B551	200	20	20



6820

codice code código														A mm		per articolo for code			MIN ORD
1	2	3	4	5	6	7	8	9	10	11	12	13	14						
6	8	2	0	•	0	0	0	C	•	0	2	0	0	30	7100.1300	B551	100	10	10
6	8	2	0	•	0	0	0	D	•	0	2	0	0	35	7100.1300	B551	100	10	10
6	8	2	0	•	0	0	0	E	•	0	2	0	0	40	7100.1300	B551	100	10	10
6	8	2	0	•	0	0	0	F	•	0	2	0	0	45	7100.1300	B551	100	10	10
6	8	2	0	•	0	0	0	G	•	0	2	0	0	50	7100.1300	B551	100	10	10
6	8	2	0	•	0	0	0	H	•	0	2	0	0	55	7100.1300	B551	100	10	10
6	8	2	0	•	0	0	0	I	•	0	2	0	0	60	7100.1300	B551	100	10	10
6	8	2	0	•	0	0	0	L	•	0	2	0	0	65	7100.1300	B551	100	10	10
6	8	2	0	•	0	0	0	M	•	0	2	0	0	70	7100.1300	B551	100	10	10
6	8	2	0	•	0	0	0	N	•	0	2	0	0	85	7100.1300	B551	100	10	10
6	8	2	0	•	0	0	0	P	•	0	2	0	0	95	7100.1300	B551	100	10	10



CILINDRI DI RICAMBIO



SPARE CYLINDERS

CYLINDRES DÉTACHÉES

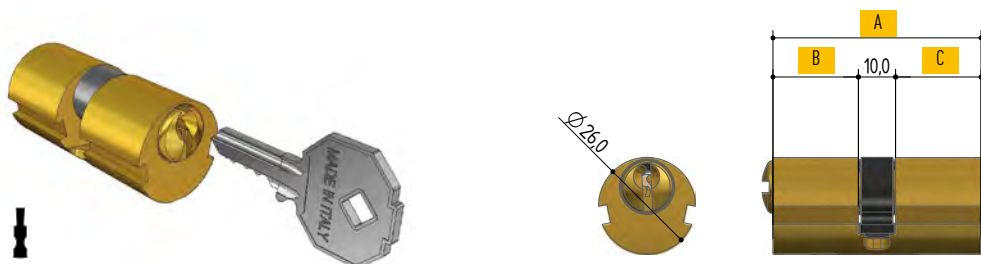
CILINDROS DE REPUESTO



6842

codice code código														A	B	C		per articolo for code			MIN ORD
1	2	3	4	5	6	7	8	9	10	11	12	13	14	mm	mm	mm					
6	8	4	2	•	0	0	0	0	•	0	2	0	0	56	23	23	7100.1300	5520	50	5	5
6	8	4	2	•	0	0	0	2	•	0	2	0	0	63	23	30	7100.1300	5520	50	5	5
6	8	4	2	•	0	0	0	4	•	0	2	0	0	75	23	42	7100.1300	5520	50	5	5
6	8	4	2	•	0	0	0	6	•	0	2	0	0	80	23	47	7100.1300	5520	50	5	5
6	8	4	2	•	0	0	0	8	•	0	2	0	0	85	33	42	7100.1300	5520	50	5	5
6	8	4	2	•	0	0	0	A	•	0	2	0	0	70	23	37	7100.1300	5520	50	5	5



CILINDRO EUROPEO
EUROPEAN PROFILE CYLINDER
 CYLINDRE À PROFIL EUROPÉEN
 CILINDRO DE PERFIL EUROPEO



W

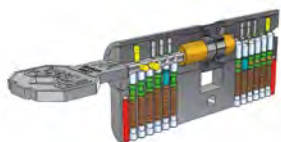

Chiave di sicurezza
 Max 9 perni di cifratura:
 6 perni in acciaio inox
 3 perni passivi in ottone
 Max. 5 contoperni a doppio fungo anti grimaldello carbonitrurati e nichelati e 1 contoperno antibumping
 Finitura sabbata nichelato opaco
 Combinazioni max 3.286.080
 Spina antitrapano
 Possibilità chiave da cantiere
 Broccia asimmetrica
 Palettone DIN

Security key
 Max 9 bitting pins:
 6 stainless steel pins
 3 passive brass pins
 Max 5 double mushroom carbonitrided and nickel-plated anti-picking counterpins and 1 anti-bumping counter pin
 Matt nickel sandblasted finish
 Max combinations 3.286.080
 Drill-resistant pin
 Construction key on request
 Asymmetrical broach
 DIN cam

Clé de sécurité
 Max 9 goupilles :
 6 goupilles en acier inoxydable
 3 goupilles passives en laiton
 Max 5 contre-goupilles anti-picking carbonitrurées et nickelées double champignon et 1 contre-goupille anti-bumping
 Finition sablée nickel mat
 Combinaisons max 3.286.080
 Goupille anti-perçage
 Clé de chantier sur demande
 Broche asymétrique
 DIN cam

Llave de seguridad
 Max 6 pitones :
 6 pitones de acero inoxidable
 3 pitones de latón pasivos
 Max 5 contrapitones doble seta anti-picking carbonitrurados y niquelados y 1 contrapiton anti-bumping
 Acabado arenado níquel mate
 Combinaciones máximas 3.286.080
 Clavija antitaladro
 Llave de obra bajo demanda
 Broche asimétrico
 DIN cam

6



Max 5 perni di cifratura in ottone
 Finitura ottone naturale/nichelato lucido
 Combinazioni max 1000
 Broccia asimmetrica

Max 5 brass bitting pins
 Natural brass / polished nickel finish
 Max keyngs 1000
 Asymmetrical broach

Max 5 broches mordantes en laiton
 Laiton naturel / finition nickel poli
 Combinaisons max 1000
 Broche asymétrique

Max 5 pitones de mordida de latón
 Latón natural / acabado níquel pulido
 Combinaciones máximas 1000
 Broche asimétrico

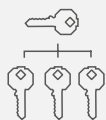

POSSIBILITÀ MK (CHIAVE MAESTRA) SU TUTTI I CILINDRI A PROFILO
MK (MASTER KEY) AVAILABLE ON ALL EUROPEAN PROFILE CYLINDERS
 POSSIBILITÉ MK (CLE PASSE-PARTOUT) SUR TOUS LES CILINDRES À PROFIL EUROPÉEN
 POSIBILIDAD MK (LLAVE MAESTRA) EN TODOS LOS CILINDROS DE PERFIL EUROPEO



CLASSICA A PROFILO

SERRATURE PER PORTE BASCULANTI A CILINDRO PROFILO EUROPEO INT. 70

LOCKS FOR OVERHEAD GARAGE DOORS WITH EUROPEAN PROFILE CYLINDER INT. 70

SERRURES POUR PORTES BASCULANTES, CYLINDRE PROFILE EUROPÉEN - ENTRAXE 70

CERRADURAS PARA PUERTAS BASCULANTES, CILINDRO DE PERFIL EUROPEO - DISTANCIA ENTRE EJES 70



A = 70mm

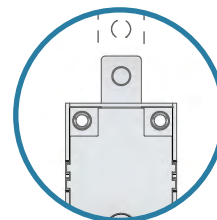
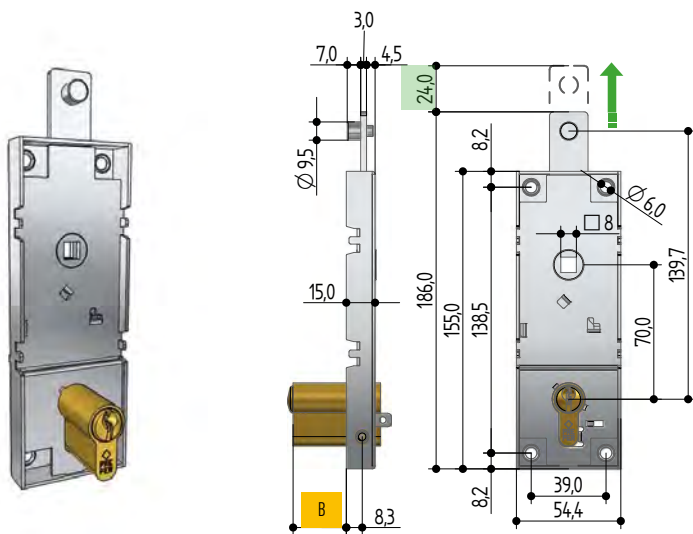

- + Perno / foro
Pin / hole
 - 6 bolt hole - M6
 - 8 bolt hole - M8
 - A No pin

- + Quadro maniglia / Handle hole
Carré de poignée / Perno cuadrado
 - 7 7 x 7 mm
 - 9 9 x 9 mm

- Z Senza cilindro
Without cylinder
Sans cylindre
Sin cilindro

W561



codice code código														B mm					MIN ORD.
1	2	3	4	5	6	7	8	9	10	11	12	13	14						
W	5	6	1	•	0	8	2	0	•	0	0	0	0	15,2	WE0S.2410	7300.2A00	40	1	10
W	5	6	1	•	0	8	2	2	•	0	0	0	0	22,7	WE0S.3110	7300.2B00	40	1	1

B561

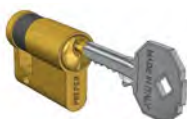

codice code código														B mm					MIN ORD.
1	2	3	4	5	6	7	8	9	10	11	12	13	14						
B	5	6	1	•	0	8	1	Z	•	0	0	0	0	-	-	-	40	1	10
B	5	6	1	•	0	8	1	0	•	0	2	0	0	13,7	6A00.2210	7100.2300	40	1	10
B	5	6	1	•	0	8	1	2	•	0	2	0	0	21,7	6A00.3010	7100.2400	40	1	1
B	5	6	1	•	0	8	1	4	•	0	2	0	0	31,7	6A00.4010	7100.2400	40	1	1



FUNZIONE BI-STABILE (SERRATURA SENZA RIARMO AUTOMATICO)

RE-ARMLESS FUNCTION - FONCTION SANS RÉARMEMENT AUTOMATIQUE - FUNCIÓN SIN REARME AUTOMÁTICO

W5B1



codice code código														B mm					MIN ORD.
1	2	3	4	5	6	7	8	9	10	11	12	13	14						
W	5	B	1	•	0	8	2	0	•	0	0	0	0	15,2	WE2S.2410	7300.2A00	40	1	10
W	5	B	1	•	0	8	2	2	•	0	0	0	0	22,7	WE2S.3110	7300.2B00	40	1	1

B5B1



codice code código														B mm					MIN ORD.
1	2	3	4	5	6	7	8	9	10	11	12	13	14						
B	5	B	1	•	0	8	1	Z	•	0	0	0	0	-	-	-	40	1	10
B	5	B	1	•	0	8	1	0	•	0	2	0	0	13,7	6A20.2210	7100.2300	40	1	10
B	5	B	1	•	0	8	1	2	•	0	2	0	0	21,7	6A20.3010	7100.2400	40	1	1
B	5	B	1	•	0	8	1	4	•	0	2	0	0	31,7	6A20.4010	7100.2400	40	1	1



**ANTI-EFFRAZIONE
SENZA LEVA
INTERNA**

SERRATURE PER PORTE BASCULANTI A CILINDRO PROFILO EUROPEO INT. 70

LOCKS FOR OVERHEAD GARAGE DOORS WITH EUROPEAN PROFILE CYLINDER INT. 70

SERRURES POUR PORTES BASCULANTES, CYLINDRE PROFILE EUROPÉEN - ENTRAXE 70

CERRADURAS PARA PUERTAS BASCULANTES, CILINDRO DE PERFIL EUROPEO - DISTANCIA ENTRE EJES 70



B5A1.0811-W5A1.0821

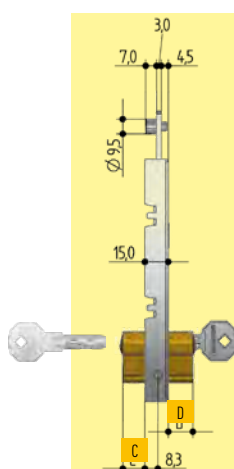

B5A1.081B-W5A1.082B

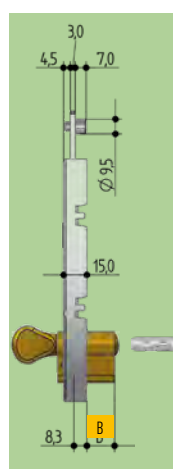

A = 70mm

- + Perno / foro
Pin / hole
 - 6 bolt hole - M6
 - 8 bolt hole - M8
 - A No pin
- + Quadro maniglia / Handle hole
Carré de poignée / Perno cuadrado
 - 7 7 x 7 mm
 - 9 9 x 9 mm

W5A1



codice code código														B mm	C mm	D mm					MIN	ORD
1	2	3	4	5	6	7	8	9	10	11	12	13	14									
W	5	A	1	•	0	8	2	1	•	0	0	0	0	15,7	17,3	WMAS.2424	7300.2A00	40	1	10		
W	5	A	1	•	0	8	2	B	•	0	0	0	0	15,3	-	WLAS.2410	7300.2A00	40	1	1		

B5A1



codice code código														B mm	C mm	D mm					MIN	ORD
1	2	3	4	5	6	7	8	9	10	11	12	13	14									
B	5	A	1	•	0	8	1	1	•	0	2	0	0	-	13,7	6HA0.2222	7100.1300	40	1	10		
B	5	A	1	•	0	8	1	B	•	0	0	0	0	17,3	-	6KA0.2610	7100.2400	40	1	1		



FUNZIONE BI-STABILE (SERRATURA SENZA RIARMO AUTOMATICO)

RE-ARMLESS FUNCTION - FONCTION SANS RÉARMEMENT AUTOMATIQUE - FUNCIÓN SIN REARME AUTOMÁTICO

W5D1



codice code código														B mm	C mm	D mm					MIN	ORD
1	2	3	4	5	6	7	8	9	10	11	12	13	14									
W	5	D	1	•	0	8	2	1	•	0	0	0	0	15,7	17,3	WMAS.2424	7300.2A00	40	1	10		
W	5	D	1	•	0	8	2	B	•	0	0	0	0	15,3	-	WLAS.2410	7300.2A00	40	1	1		

B5D1



codice code código														B mm	C mm	D mm					MIN	ORD
1	2	3	4	5	6	7	8	9	10	11	12	13	14									
B	5	D	1	•	0	8	1	1	•	0	2	0	0	-	13,7	6HA0.2222	7100.1300	40	1	10		
B	5	D	1	•	0	8	1	B	•	0	0	0	0	17,3	-	6KA0.2610	7100.2400	40	1	1		



**ANTI-EFFRAZIONE
MANIGLIA IN FOLLE**

SERRATURE PER PORTE BASCULANTI A CILINDRO PROFILO EUROPEO INT. 70

LOCKS FOR OVERHEAD GARAGE DOORS WITH EUROPEAN PROFILE CYLINDER INT. 70

SERRURES POUR PORTES BASCULANTES, CYLINDRE PROFILE EUROPÉEN - ENTRAXE 70

CERRADURAS PARA PUERTAS BASCULANTES, CILINDRO DE PERFIL EUROPEO - DISTANCIA ENTRE EJES 70



A = 70mm

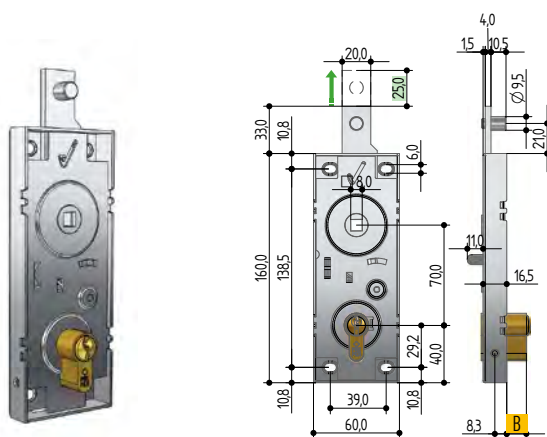

+ Perno / foro
Pin / hole

6	bolt hole - M6
8	bolt hole - M8
A	No pin

+ Quadro maniglia / Handle hole
Carré de poignée / Perno cuadrado

7	7 x 7 mm
9	9 x 9 mm

W598



codice code código														B mm					
1	2	3	4	5	6	7	8	9	10	11	12	13	14						
W	5	9	8	•	0	8	2	0	•	0	0	0	0	15,2	WE0S.2410	7300.2A00	40	1	1
W	5	9	8	•	0	8	2	2	•	0	0	0	0	22,7	WE0S.3110	7300.2B00	40	1	1

6598

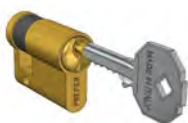

codice code código														B mm					
1	2	3	4	5	6	7	8	9	10	11	12	13	14						
6	5	9	8	•	0	8	1	Z		0	0	0	0	-	-	-	40	1	1
6	5	9	8	•	0	8	1	0		0	2	0	0	13,7	6A00.2210	7100.2300	40	1	1
6	5	9	8	•	0	8	1	2	•	0	2	0	0	21,7	6A00.3010	7100.2400	40	1	1
6	5	9	8	•	0	8	1	4	•	0	2	0	0	31,7	6A00.4010	7100.2400	40	1	1

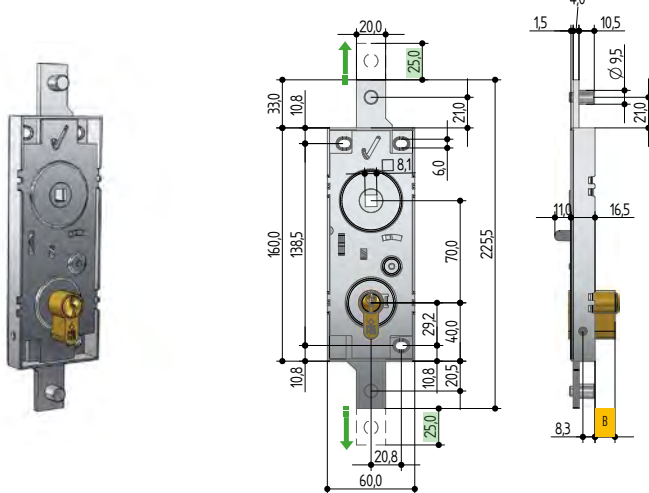

Z Senza cilindro
Without cylinder
Sans cylindre
Sin cilindro

W599



codice code código														B mm					
1	2	3	4	5	6	7	8	9	10	11	12	13	14						
W	5	9	9	•	0	8	2	0	•	0	0	0	0	15,2	WE2S.2410	7300.2A00	20	1	1
W	5	9	9	•	0	8	2	2	•	0	0	0	0	22,7	WE2S.3110	7300.2B00	20	1	1

6599



codice code código														B mm					
1	2	3	4	5	6	7	8	9	10	11	12	13	14						
6	5	9	9	•	0	8	1	Z		0	0	0	0	-	-	-	20	1	10
6	5	9	9	•	0	8	1	0		0	2	0	0	13,7	6A20.2210	7100.2300	20	1	10
6	5	9	9	•	0	8	1	2	•	0	2	0	0	21,7	6A20.3010	7100.2400	20	1	1
6	5	9	9	•	0	8	1	4	•	0	2	0	0	31,7	6A20.4010	7100.2400	20	1	1



CROCE

SERRATURE PER PORTE BASCULANTI A CILINDRO PROFILO EUROPEO INT. 70

LOCKS FOR OVERHEAD GARAGE DOORS WITH EUROPEAN PROFILE CYLINDER INT. 70

SERRURES POUR PORTES BASCULANTES, CYLINDRE PROFILE EUROPÉEN - ENTRAXE 70

CERRADURAS PARA PUERTAS BASCULANTES, CILINDRO DE PERFIL EUROPEO - DISTANCIA ENTRE EJES 70



SERRATURE MADE IN ITALY



A = 70mm

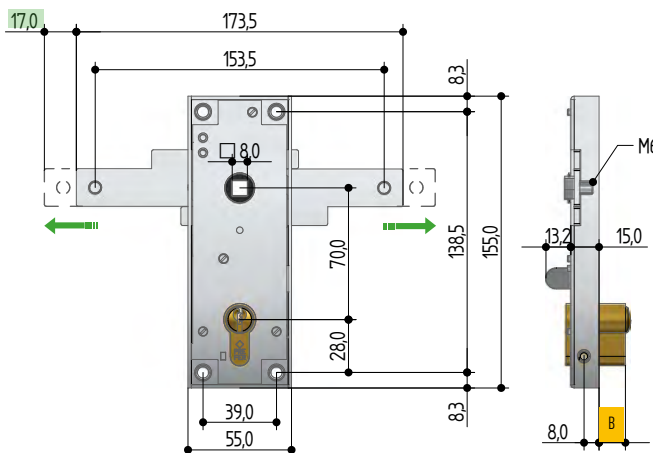
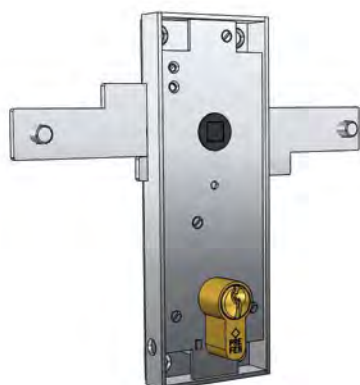

+

Quadro maniglia / Handle hole
Carré de poignée / Perno cuadrado

7 7 x 7 mm
9 9 x 9 mm

Z Senza cilindro
Without cylinder
Sans cylindre
Sin cilindro

CATENACCIO SENZA MOLLA DI RITORNO

BOLT WITHOUT RETURNING SPRING LATCH - PÊNE DORMANT SANS RESSORT DE RAPPEL - CERROJO SIN RESORTE DE RETORNO

W562



codice code código														B mm					MIN	ORD
1	2	3	4	5	6	7	8	9	10	11	12	13	14							
W	5	6	2	•	0	8	2	0	•	0	0	0	0	15,2	WE0S.2410	7300.2A00	20	5	5	
W	5	6	2	•	0	8	2	2	•	0	0	0	0	22,7	WE0S.3110	7300.2B00	20	5	5	

6562

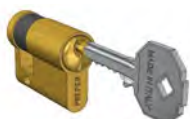

codice code código														B mm					MIN	ORD
1	2	3	4	5	6	7	8	9	10	11	12	13	14							
6	5	6	2	•	0	8	1	Z	•	0	0	0	0	-	-	-	20	5	5	
6	5	6	2	•	0	8	1	0	•	0	2	0	0	13,7	6A00.2210	7100.2300	20	5	5	
6	5	6	2	•	0	8	1	2	•	0	2	0	0	21,7	6A00.3010	7100.2400	20	5	5	
6	5	6	2	•	0	8	1	4	•	0	2	0	0	31,7	6A00.4010	7100.2400	20	5	5	

CATENACCIO CON MOLLA DI RITORNO

BOLT WITH RETURNING SPRING LATCH - PÊNE DORMANT AVEC RESSORT DE RAPPEL - CERROJO CON RESORTE DE RETORNO

W563



codice code código														B mm					MIN	ORD
1	2	3	4	5	6	7	8	9	10	11	12	13	14							
W	5	6	3	•	0	8	2	0	•	0	0	0	0	15,2	WE0S.2410	7300.2A00	20	5	5	
W	5	6	3	•	0	8	2	2	•	0	0	0	0	22,7	WE0S.3110	7300.2B00	20	5	5	

6563



codice code código														B mm					MIN	ORD
1	2	3	4	5	6	7	8	9	10	11	12	13	14							
6	5	6	3	•	0	8	1	Z	•	0	0	0	0	-	-	-	20	5	5	
6	5	6	3	•	0	8	1	0	•	0	2	0	0	13,7	6A00.2210	7100.2300	20	5	5	
6	5	6	3	•	0	8	1	2	•	0	2	0	0	21,7	6A00.3010	7100.2400	20	5	5	
6	5	6	3	•	0	8	1	4	•	0	2	0	0	31,7	6A00.4010	7100.2400	20	5	5	



TRIPLICE

SERRATURE PER PORTE BASCULANTI A CILINDRO PROFILO EUROPEO INT. 70

LOCKS FOR OVERHEAD GARAGE DOORS WITH EUROPEAN PROFILE CYLINDER INT. 70

SERRURES POUR PORTES BASCULANTES, CYLINDRE PROFILE EUROPÉEN - ENTRAXE 70

CERRADURAS PARA PUERTAS BASCULANTES, CILINDRO DE PERFIL EUROPEO - DISTANCIA ENTRE EJES 70



SERRATURE MADE IN ITALY



A = 70mm

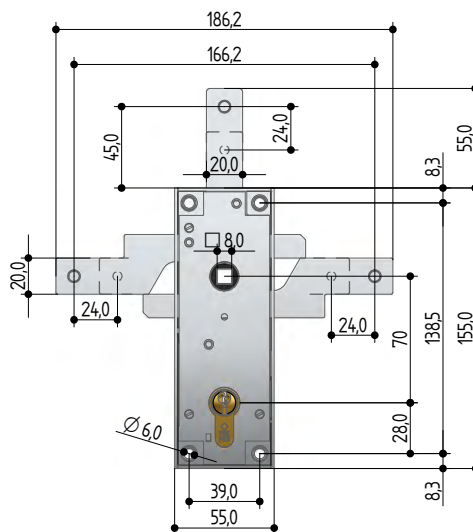
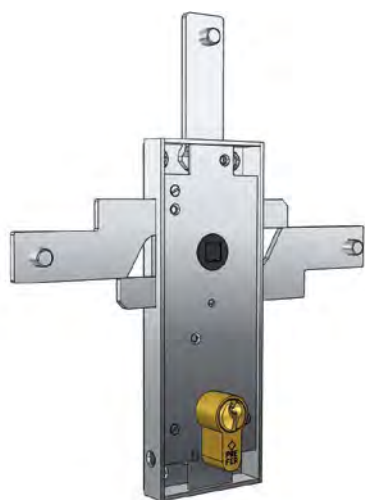

+ Quadro maniglia / Handle hole
Carré de poignée / Perno cuadrado

7	7 x 7 mm
9	9 x 9 mm

Z Senza cilindro
Without cylinder
Sans cylindre
Sin cilindro

W574

codice code código														B mm					MIN	ORD
1	2	3	4	5	6	7	8	9	10	11	12	13	14							
W	5	7	4	•	6	8	2	0	•	0	0	0	0	16,0	WEOS.2410	7300.2A00	20	5	5	
W	5	7	4	•	6	8	2	2	•	0	0	0	0	23	WEOS.3110	7300.2B00	20	5	5	



6574

codice code código														B mm					MIN	ORD
1	2	3	4	5	6	7	8	9	10	11	12	13	14							
6	5	7	4	•	6	8	1	Z	•	0	0	0	0	-	-	-	20	5	5	
6	5	7	4	•	6	8	1	0	•	0	2	0	0	14,0	6A00.2210	7100.2300	20	5	5	
6	5	7	4	•	6	8	1	2	•	0	2	0	0	22,0	6A00.3010	7100.2400	20	5	5	
6	5	7	4	•	6	8	1	4	•	0	2	0	0	32,0	6A00.4010	7100.2400	20	5	5	

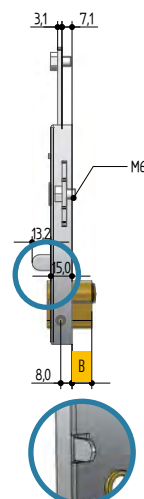
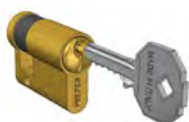

W584

codice code código														B mm					MIN	ORD
1	2	3	4	5	6	7	8	9	10	11	12	13	14							
W	5	8	4	•	6	8	2	0	•	0	0	0	0	16	WEOS.2410	7300.2A00	20	5	5	
W	5	8	4	•	6	8	2	2	•	0	0	0	0	23	WEOS.3110	7300.2B00	20	5	5	



6584

codice code código														B mm					MIN	ORD
1	2	3	4	5	6	7	8	9	10	11	12	13	14							
6	5	8	4	•	6	8	1	Z	•	0	0	0	0	-	-	-	20	5	5	
6	5	8	4	•	6	8	1	0	•	0	2	0	0	14,0	6A00.2210	7100.2300	20	5	5	
6	5	8	4	•	6	8	1	2	•	0	2	0	0	22,0	6A00.3010	7100.2400	20	5	5	
6	5	8	4	•	6	8	1	4	•	0	2	0	0	32,0	6A00.4010	7100.2400	20	5	5	





SPECIALI

SERRATURA CON DOPPIA ROTAZIONE DELLA MANIGLIA PER L'APERTURA DELLA PORTA BASCULANTE E DELLA PORTA PEDONALE INT 70

DEVICE WITH DOUBLE ROTATION OF THE HANDLE FOR OPENING BOTH PEDESTRIAN DOOR AND GARAGE DOOR

DISPOSITIF A DOUBLE ROTATION DE LA POIGNEE POUR OUVRIR A LA FOIS LA PORTE PIETONNE ET LA PORTE DE GARAGE

DISPOSITIVO CON DOBLE ROTACIÓN DE MANILLA PARA APERTURA TANTO PUERTA PEATONAL COMO PUERTA DE GARAJE



A = 70mm

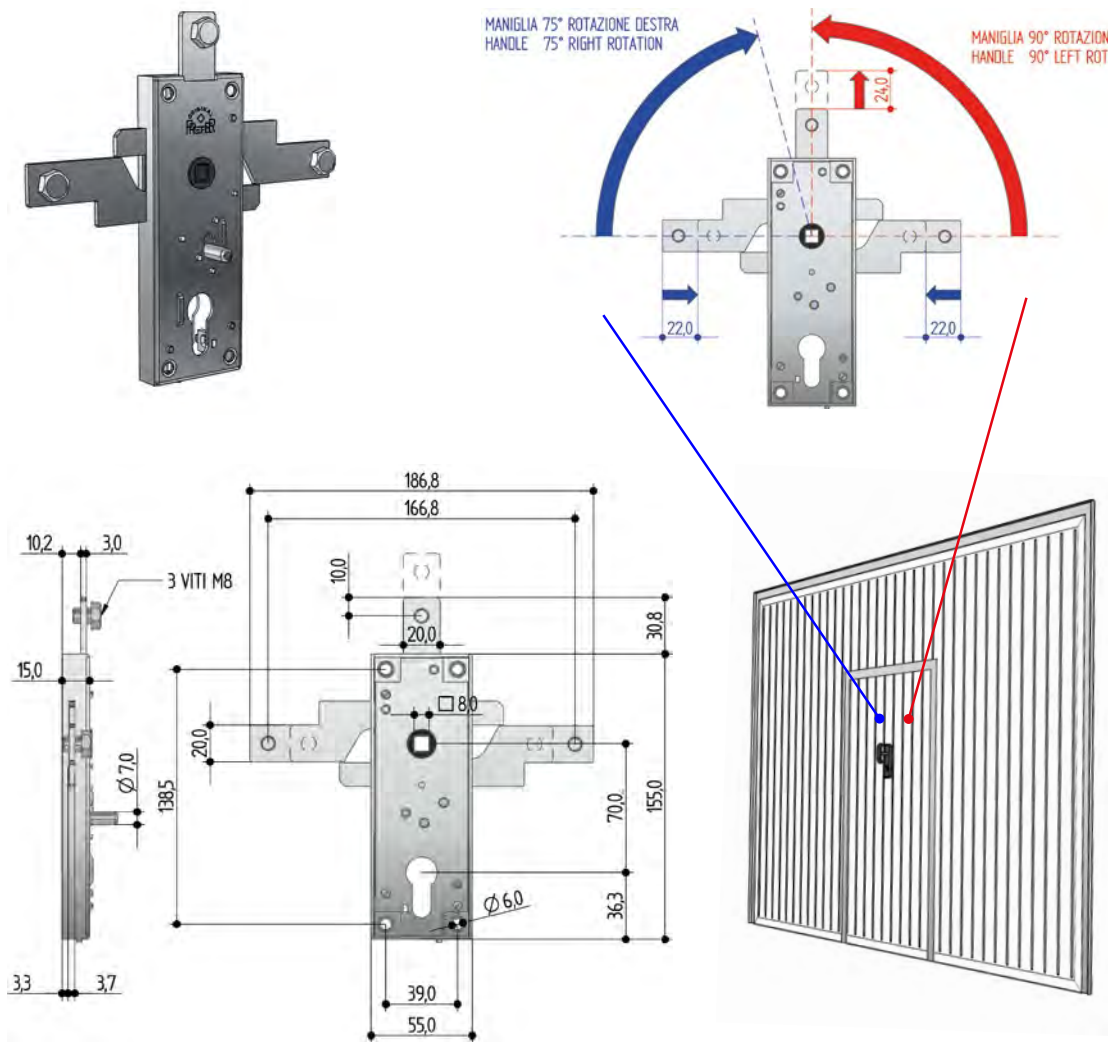

Per aprire la porta pedonale ruotare 75° a destra
To open the pedestrian door, turn 75° to the right
Pour ouvrir la porte piétonnel, tourner 75 à droite
para abrir la puerta peatonal, gire la manilla 75° hacia la derecha

Per aprire la porta basculante ruotare la maniglia 90° a sinistra
To open the overhead door rotate the handle 90° to the left.
Pour ouvrir la porte basculante, tournez la poignée 90° à gauche
Para abrir la puerta basculante, gire la manilla 90° hacia la izquierda

65C1
CALLUS

codice code código														MIN		ORD		
1	2	3	4	5	6	7	8	9	10	11	12	13	14	20	5	5		
6	5	C	1	•	8	8	1	Z	•	0	0	0	0					

+

Quadro maniglia / Handle hole
Carré de poignée / Perno cuadrado

7 7 x 7 mm
9 9 x 9 mm

Z Senza cilindro
Without cylinder
Sans cylindre
Sin cilindro



DIN

SERRATURE PER PORTE BASCULANTI A CILINDRO PROFILO EUROPEO INT. 60

LOCKS FOR OVERHEAD GARAGE DOORS WITH EUROPEAN PROFILE CYLINDER INT. 60

SERRURES POUR PORTES BASCULANTES, CYLINDRE PROFILE EUROPÉEN - ENTRAXE 60

CERRADURAS PARA PUERTAS BASCULANTES, CILINDRO DE PERFIL EUROPEO - DISTANCIA ENTRE EJES 60



A = 60mm

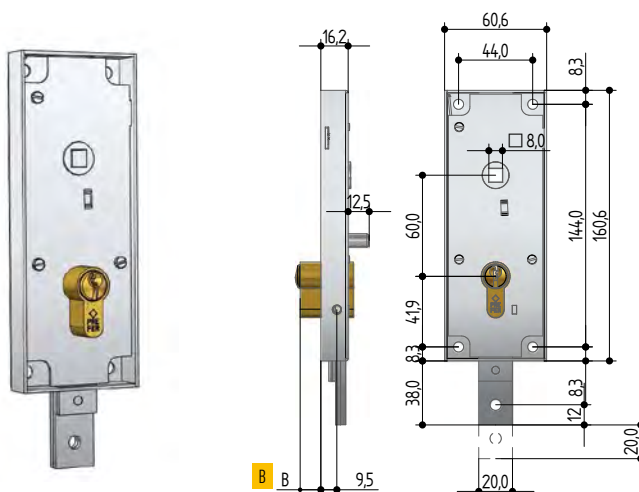

+ Quadro maniglia / Handle hole
Carré de poignée / Perno cuadrado

7 7 x 7 mm

9 9 x 9 mm

Z Senza cilindro
Without cylinder
Sans cylindre
Sin cilindro

CATENACCIO CON MOLLA DI RITORNO

BOLT WITH RETURNING SPRING LATCH - PÊNE DORMANT AVEC RESSORT DE RAPPEL - CERROJO CON RESORTE DE RETORNO

W564

codice code código														B mm					MIN ORD
1	2	3	4	5	6	7	8	9	10	11	12	13	14						
W	5	6	4	•	0	8	2	0	•	0	0	0	0	14,3	WE0S.2410	7300.2A00	20	1	1
W	5	6	4	•	0	8	2	2	•	0	0	0	0	21,3	WE0S.3110	7300.2B00	20	1	1



6564

codice code código														B mm					MIN ORD
1	2	3	4	5	6	7	8	9	10	11	12	13	14						
6	5	6	4	•	0	8	1	Z		0	0	0	0	-	-	-	20	1	10
6	5	6	4	•	0	8	1	0		0	2	0	0	12,3	6A00.2210	7100.2300	20	1	10
6	5	6	4	•	0	8	1	2	•	0	2	0	0	20,3	6A00.3010	7100.2400	20	1	1
6	5	6	4	•	0	8	1	4	•	0	2	0	0	30,3	6A00.4010	7100.2400	20	1	1

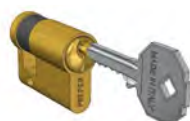

CATENACCIO SENZA MOLLA DI RITORNO

BOLT WITHOUT RETURNING SPRING LATCH - PÊNE DORMANT SANS RESSORT DE RAPPEL - CERROJO SIN RESORTE DE RETORNO

W565

codice code código														B mm					MIN ORD
1	2	3	4	5	6	7	8	9	10	11	12	13	14						
W	5	6	5	•	0	8	2	0	•	0	0	0	0	14,3	WE0S.2410	7300.2A00	20	1	1
W	5	6	5	•	0	8	2	2	•	0	0	0	0	21,3	WE0S.3110	7300.2B00	20	1	1



6565

codice code código														B mm					MIN ORD
1	2	3	4	5	6	7	8	9	10	11	12	13	14						
6	5	6	5	•	0	8	1	Z		0	0	0	0	-	-	-	20	1	10
6	5	6	5	•	0	8	1	0		0	2	0	0	12,3	6A00.2210	7100.2300	20	1	10
6	5	6	5	•	0	8	1	2	•	0	2	0	0	20,3	6A00.3010	7100.2400	20	1	1
6	5	6	5	•	0	8	1	4	•	0	2	0	0	30,3	6A00.4010	7100.2400	20	1	1

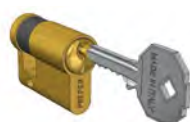



DIN

SERRATURE PER PORTE BASCULANTI A CILINDRO PROFILO EUROPEO INT. 60

LOCKS FOR OVERHEAD GARAGE DOORS WITH EUROPEAN PROFILE CYLINDER INT. 60

SERRURES POUR PORTES BASCULANTES, CYLINDRE PROFILE EUROPÉEN - ENTRAXE 60

CERRADURAS PARA PUERTAS BASCULANTES, CILINDRO DE PERFIL EUROPEO - DISTANCIA ENTRE EJES 60



A = 60mm

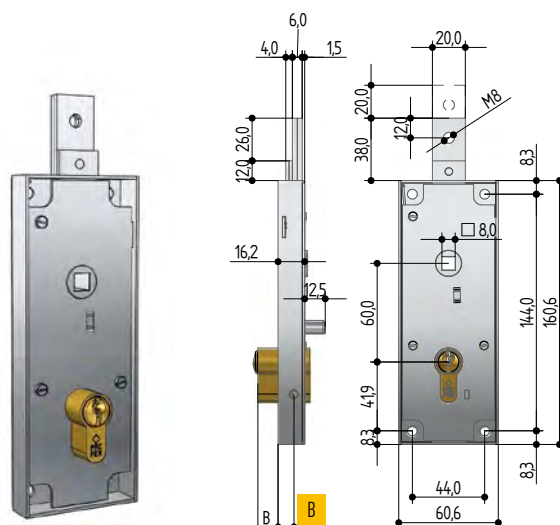

+

Quadro maniglia / Handle hole
Carré de poignée / Perno cuadrado

7 7 x 7 mm
9 9 x 9 mm

Z Senza cilindro
Without cylinder
Sans cylindre
Sin cilindro

CATENACCIO CON MOLLA DI RITORNO

BOLT WITH RETURNING SPRING LATCH - PÊNE DORMANT AVEC RESSORT DE RAPPEL - CERROJO CON RESORTE DE RETORNO

W566

codice code código														B mm					MIN ORD
1	2	3	4	5	6	7	8	9	10	11	12	13	14						
W	5	6	6	•	0	8	2	0	•	0	0	0	0	14,3	WE0S.2410	7300.2A00	20	1	1
W	5	6	6	•	0	8	2	2	•	0	0	0	0	21,3	WE0S.3110	7300.2B00	20	1	1



6566

codice code código														B mm					MIN ORD
1	2	3	4	5	6	7	8	9	10	11	12	13	14						
6	5	6	6	•	0	8	1	Z		0	0	0	0	-	-	-	20	1	10
6	5	6	6	•	0	8	1	0		0	2	0	0	12,3	6A00.2210	7100.2300	20	1	10
6	5	6	6	•	0	8	1	2	•	0	2	0	0	20,3	6A00.3010	7100.2400	20	1	1
6	5	6	6	•	0	8	1	4	•	0	2	0	0	30,3	6A00.4010	7100.2400	20	1	1

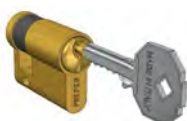

CATENACCIO SENZA MOLLA DI RITORNO

BOLT WITHOUT RETURNING SPRING LATCH - PÊNE DORMANT SANS RESSORT DE RAPPEL - CERROJO SIN RESORTE DE RETORNO

W567

codice code código														B mm					MIN ORD
1	2	3	4	5	6	7	8	9	10	11	12	13	14						
W	5	6	7	•	0	8	2	0	•	0	0	0	0	14,3	WE0S.2410	7300.2A00	20	1	1
W	5	6	7	•	0	8	2	2	•	0	0	0	0	21,3	WE0S.3110	7300.2B00	20	1	1



6567

codice code código														B mm					MIN ORD
1	2	3	4	5	6	7	8	9	10	11	12	13	14						
6	5	6	7	•	0	8	1	Z		0	0	0	0	-	-	-	20	1	10
6	5	6	7	•	0	8	1	0		0	2	0	0	12,3	6A00.2210	7100.2300	20	1	10
6	5	6	7	•	0	8	1	2	•	0	2	0	0	20,3	6A00.3010	7100.2400	20	1	1
6	5	6	7	•	0	8	1	4	•	0	2	0	0	30,3	6A00.4010	7100.2400	20	1	1

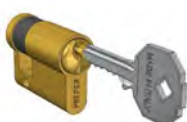



DIN SPECIALE

DISPOSITIVO CON DOPPIA ROTAZIONE DELLA MANIGLIA PER L'APERTURA DELLA PORTA BASCULANTE E DELLA PORTA PEDONALE

DEVICE WITH DOUBLE ROTATION OF THE HANDLE FOR OPENING BOTH PEDESTRIAN DOOR AND GARAGE DOOR

DISPOSITIF A DOUBLE ROTATION DE LA POIGNEE POUR OUVRIR A LA FOIS LA PORTE PIETONNE ET LA PORTE DE GARAGE

DISPOSITIVO CON DOBLE ROTACIÓN DE MANILLA PARA APERTURA TANTO PUERTA PEATONAL COMO PUERTA DE GARAJE



A = 60mm



MANIGLIA 45° ROTAZIONE DESTRA
HANDLE 45° RIGHT ROTATION

MANIGLIA 30° ROTAZIONE SINISTRA
HANDLE 30° LEFT ROTATION

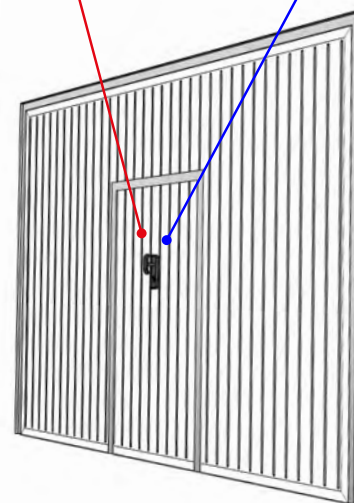
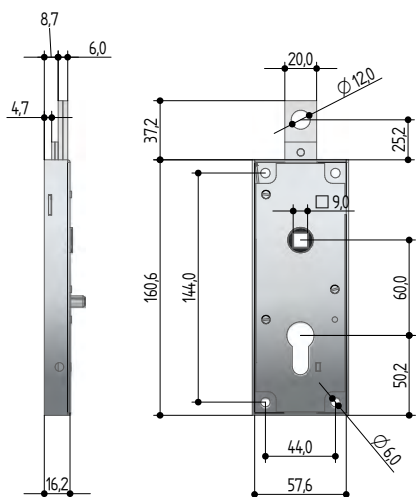
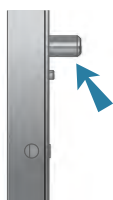
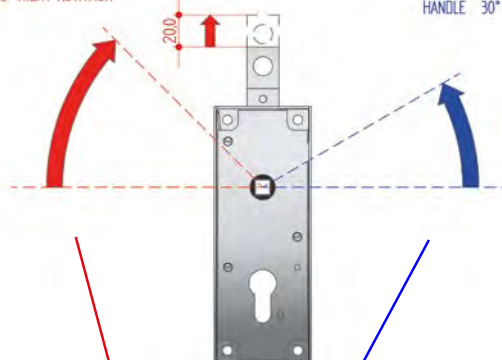

Per aprire la porta basculante ruotare la maniglia 45° a destra
To open the overhead door rotate the handle 45° to the right
Pour ouvrir la porte basculante, tournez la poignée 45° à droite
Para abrir la puerta basculante, gire la manilla 45° hacia la derecha

Per aprire la porta pedonale ruotare 30° a sinistra
To open the pedestrian door, turn 30° to the left
Pour ouvrir la porte piétonnel, tourner 30° à gauche
para abrir la puerta peatonal, gire la manilla 30° hacia la izquierda

65B2
CALLUS

codice code código																
1	2	3	4	5	6	7	8	9	10	11	12	13	14			
6	5	B	2	•	C	9	1	Z	•	0	0	0	0			

+ Quadro maniglia / Handle hole
Carré de poignée / Perno cuadrado

- 7 7 x 7 mm
- 9 9 x 9 mm

Z Senza cilindro
Without cylinder
Sans cylindre
Sin cilindro



DIN

SERRATURE PER PORTE BASCULANTI A CILINDRO PROFILO EUROPEO INT. 60

LOCKS FOR OVERHEAD GARAGE DOORS WITH EUROPEAN PROFILE CYLINDER INT. 60

SERRURES POUR PORTES BASCULANTES, CYLINDRE PROFILE EUROPÉEN - ENTRAXE 60

CERRADURAS PARA PUERTAS BASCULANTES, CILINDRO DE PERFIL EUROPEO - DISTANCIA EJES 60



A = 60mm

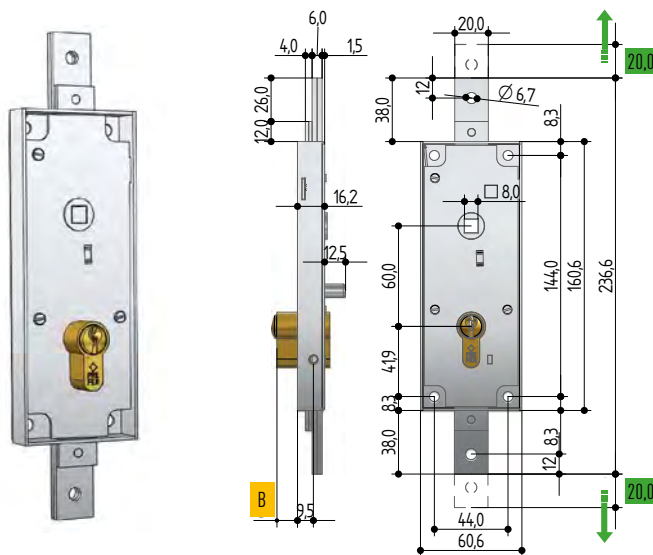

+

Quadro maniglia / Handle hole
Carré de poignée / Perno cuadrado

7 7 x 7 mm
9 9 x 9 mm

Z Senza cilindro
Without cylinder
Sans cylindre
Sin cilindro

CATENACCIO CON MOLLA DI RITORNO

BOLT WITH RETURNING SPRING LATCH - PÊNE DORMANT AVEC RESSORT DE RAPPEL - CERROJO CON RESORTE DE RETORNO

W568

codice code código														B mm					MIN ORD
1	2	3	4	5	6	7	8	9	10	11	12	13	14						
W	5	6	8	•	0	8	2	0	•	0	0	0	0	14,0	WEOS.2410	7300.2A00	20	1	1
W	5	6	8	•	0	8	2	2	•	0	0	0	0	21,5	WEOS.3110	7300.2B00	20	1	1



6568

codice code código														B mm					MIN ORD
1	2	3	4	5	6	7	8	9	10	11	12	13	14						
6	5	6	8	•	0	8	1	Z	•	0	0	0	0	-	-	-	20	1	10
6	5	6	8	•	0	8	1	0	•	0	2	0	0	12,5	6A00.2210	7100.2300	20	1	10
6	5	6	8	•	0	8	1	2	•	0	2	0	0	20,5	6A00.3010	7100.2400	20	1	1
6	5	6	8	•	0	8	1	4	•	0	2	0	0	30,5	6A00.4010	7100.2400	20	1	1

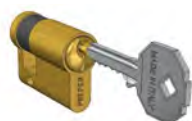

CATENACCIO SENZA MOLLA DI RITORNO

BOLT WITHOUT RETURNING SPRING LATCH - PÊNE DORMANT SANS RESSORT DE RAPPEL - CERROJO SIN RESORTE DE RETORNO

W569

codice code código														B mm					MIN ORD
1	2	3	4	5	6	7	8	9	10	11	12	13	14						
W	5	6	9	•	0	8	2	0	•	0	0	0	0	14,0	WEOS.2410	7300.2A00	20	1	1
W	5	6	9	•	0	8	2	2	•	0	0	0	0	21,5	WEOS.3110	7300.2B00	20	1	1



6569

codice code código														B mm					MIN ORD
1	2	3	4	5	6	7	8	9	10	11	12	13	14						
6	5	6	9	•	0	8	1	Z	•	0	0	0	0	-	-	-	20	1	10
6	5	6	9	•	0	8	1	0	•	0	2	0	0	12,5	6A00.2210	7100.2300	20	1	10
6	5	6	9	•	0	8	1	2	•	0	2	0	0	20,5	6A00.3010	7100.2400	20	1	1
6	5	6	9	•	0	8	1	4	•	0	2	0	0	30,5	6A00.4010	7100.2400	20	1	1

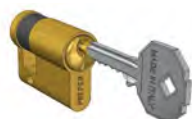



MANIGLIA IN FOLLE

SERRATURE PER PORTE BASCULANTI A CILINDRO PROFILO EUROPEO INT. 60

LOCKS FOR OVERHEAD GARAGE DOORS WITH EUROPEAN PROFILE CYLINDER INT. 60

SERRURES POUR PORTES BASCULANTES, CYLINDRE PROFILE EUROPÉEN - ENTRAXE 60

CERRADURAS PARA PUERTAS BASCULANTES, CILINDRO DE PERFIL EUROPEO - DISTANCIA ENTRE EJES 60



A = 60mm

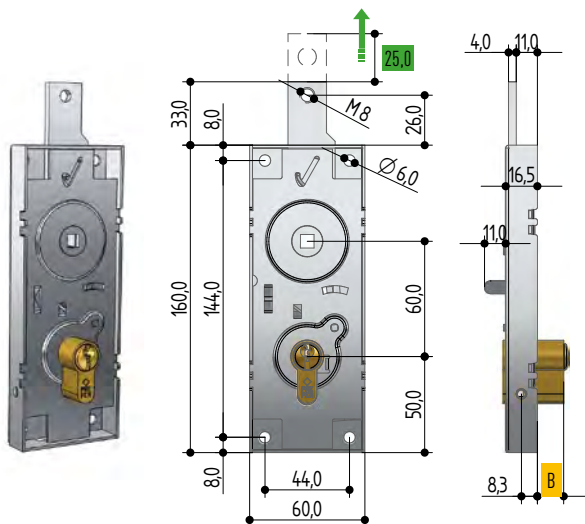

+ Quadro maniglia / Handle hole
Carré de poignée / Perno cuadrado

7	7 x 7 mm
9	9 x 9 mm

Z Senza cilindro
Without cylinder
Sans cylindre
Sin cilindro

W596

codice code código														B mm					
1	2	3	4	5	6	7	8	9	10	11	12	13	14	B mm					
W	5	9	6	•	0	8	2	0	•	0	0	0	0	15,7	WEOS.2410	7300.2A00	20	1	1
W	5	9	6	•	0	8	2	2	•	0	0	0	0	22,7	WEOS.3110	7300.2B00	20	1	1



6596

codice code código														B mm					
1	2	3	4	5	6	7	8	9	10	11	12	13	14	B mm					
6	5	9	6	•	0	8	1	Z		0	0	0	0	-	-	-	20	1	10
6	5	9	6	•	0	8	1	0		0	2	0	0	13,7	6A00.2210	7100.2300	20	1	10
6	5	9	6	•	0	8	1	2	•	0	2	0	0	21,7	6A00.3010	7100.2400	20	1	1
6	5	9	6	•	0	8	1	4	•	0	2	0	0	31,7	6A00.4010	7100.2400	20	1	1



A SERRATURA CHIUSA LA MANIGLIA NON PUÒ ESSERE FORZATA PERCHÉ GIRA LIBERAMENTE

WHEN THE LOCK IS CLOSED, THE HANDLE CANNOT BE FORCED BECAUSE IT TURNS LOOSE

À SERRURE FERMÉE, LA POIGNÉE NE PEUT PAS ÊTRE FORCÉE PARCE QUE, ELLE TOURNE LIBREMENT

A CERRADURA CERRADA LA MANIJA NO PUEDE SER FORZADA PORQUE GIRA LIBREMENTE



MANIGLIA IN FOLLE

SERRATURE PER PORTE BASCULANTI A CILINDRO PROFILO EUROPEO INT. 60

LOCKS FOR OVERHEAD GARAGE DOORS WITH EUROPEAN PROFILE CYLINDER INT. 60

SERRURES POUR PORTES BASCULANTES, CYLINDRE PROFILE EUROPÉEN - ENTRAXE 60

CERRADURAS PARA PUERTAS BASCULANTES, CILINDRO DE PERFIL EUROPEO - DISTANCIA ENTRE EJES 60



A = 60mm

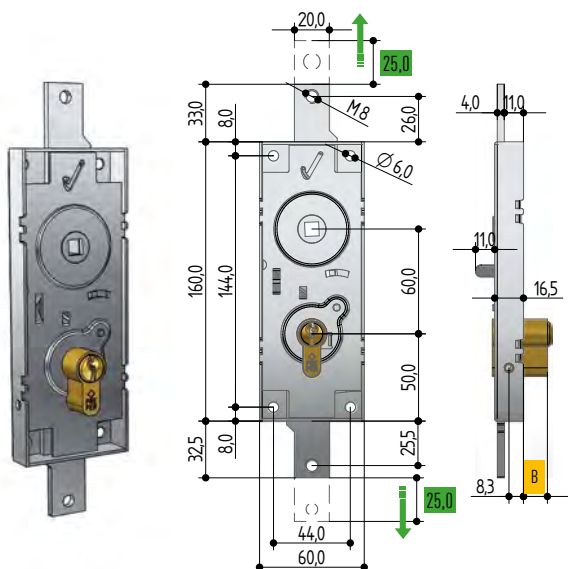

+

Quadro maniglia / Handle hole
Carré de poignée / Perno cuadrado

7	7 x 7 mm
9	9 x 9 mm

Z

Senza cilindro
Without cylinder
Sans cylindre
Sin cilindro

W597



codice code código														B mm					
1	2	3	4	5	6	7	8	9	10	11	12	13	14						
W	5	9	7	•	0	8	2	0	•	0	0	0	0	15,2	WEOS.2410	7300.2A00	20	1	1
W	5	9	7	•	0	8	2	2	•	0	0	0	0	22,7	WEOS.3110	7300.2B00	20	1	1

6597



codice code código														B mm					
1	2	3	4	5	6	7	8	9	10	11	12	13	14						
6	5	9	7	•	0	8	1	Z		0	0	0	0	-	-	-	20	1	1
6	5	9	7	•	0	8	1	0		0	2	0	0	13,7	6A00.2210	7100.2300	20	1	1
6	5	9	7	•	0	8	1	2	•	0	2	0	0	21,7	6A00.3010	7100.2400	20	1	1
6	5	9	7	•	0	8	1	4	•	0	2	0	0	31,7	6A00.4010	7100.2400	20	1	1



A SERRATURA CHIUSA LA MANIGLIA NON PUÒ ESSERE FORZATA PERCHÉ GIRA LIBERAMENTE

WHEN THE LOCK IS CLOSED, THE HANDLE CANNOT BE FORCED BECAUSE IT TURNS LOOSE

À SERRURE FERMÉE, LA POIGNÉE NE PEUT PAS ÊTRE FORCÉE PARCE QUE, ELLE TOURNE LIBREMENT

A CERRADURA CERRADA LA MANIJA NO PUEDE SER FORZADA PORQUE GIRA LIBREMENTE



CILINDRI DI RICAMBIO

SPARE CYLINDERS

CYLINDRES DÉTACHÉES

CILINDROS DE REPUESTO

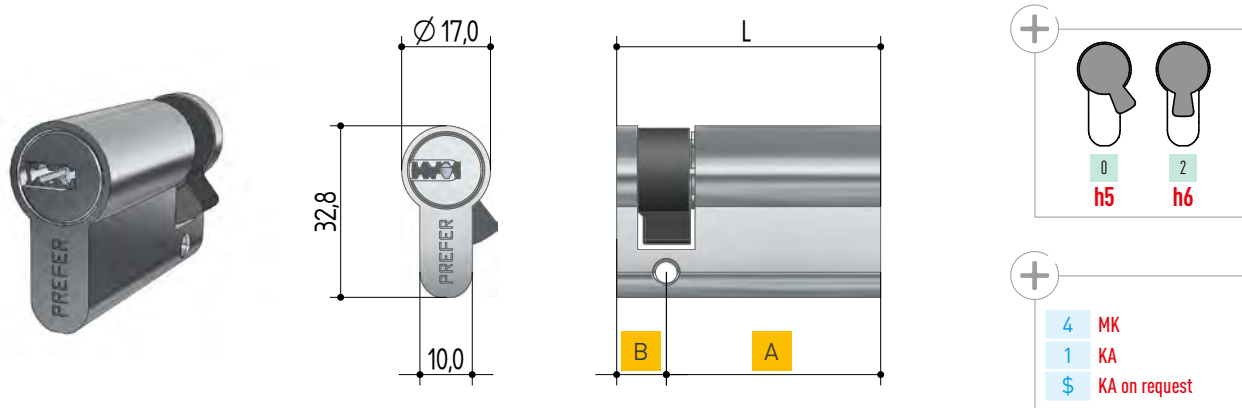

WEOS

codice code código														L mm	A mm	B mm					MIN ORD
1	2	3	4	5	6	7	8	9	10	11	12	13	14								
W	E	0	S	•	2	4	1	0	•	2	0	0	0	34	24	10	6	7300.2A00.0000	50	1	10
W	E	0	S	•	3	1	1	0	•	2	0	0	0	41	31	10	9	7300.2B00.0000	50	1	10

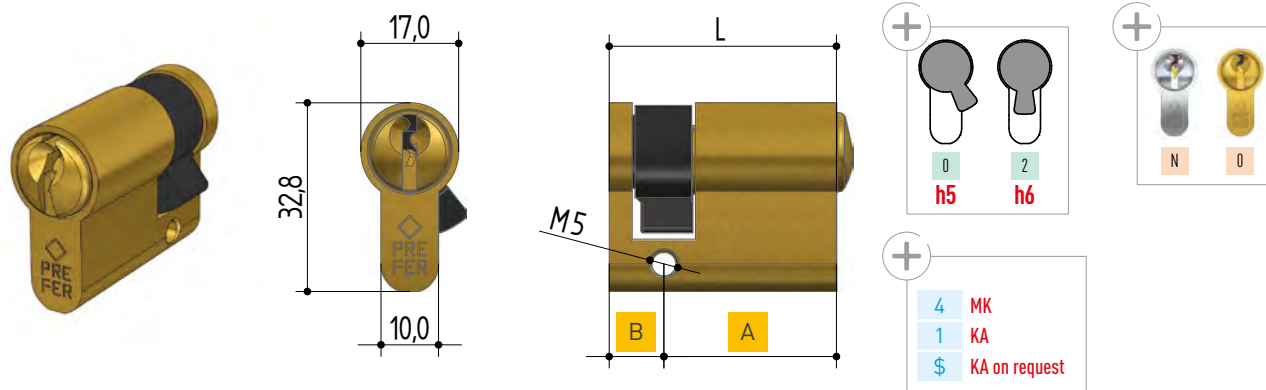

6A0N

codice code código														L mm	A mm	B mm					MIN ORD
1	2	3	4	5	6	7	8	9	10	11	12	13	14								
6	A	0	0	•	2	2	1	0	•	2	2	0	0	32	22	10	4	7100.2300.0000	100	10	10
6	A	0	0	•	3	0	1	0	•	2	2	0	0	40	30	10	5	7100.2400.0000	100	10	10
6	A	0	0	•	4	0	1	0	•	2	2	0	0	50	40	10	5	7100.2400.0000	100	10	10



CILINDRI DI RICAMBIO

SPARE CYLINDERS

CYLINDRES DÉTACHÉES

CILINDROS DE REPUESTO

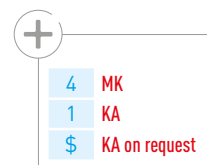
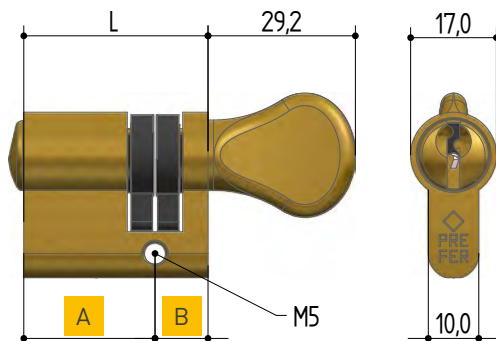
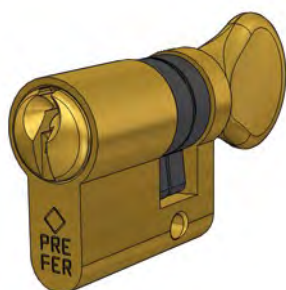

6KA0

codice code código														L	A	B			②			MIN ORD
1	2	3	4	5	6	7	8	9	10	11	12	13	14	mm	mm	mm						
6	K	A	0	•	2	6	1	0	•	2	2	0	0	36,5	26	10,5	5	7100.2400.0000	100	10	10	

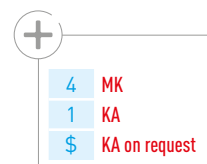
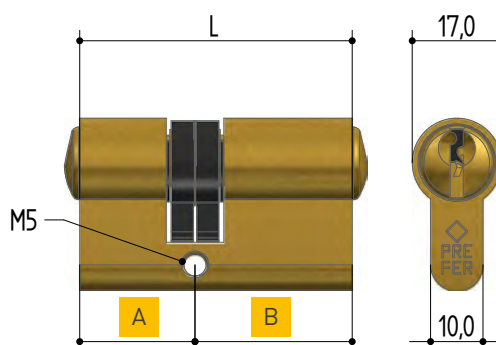

6HA0

codice code código														L	A	B			③			MIN ORD
1	2	3	4	5	6	7	8	9	10	11	12	13	14	mm	mm	mm						
6	H	A	0	•	2	6	2	6	•	2	7	0	0	52	26	26	5	7100.2400.0000	100	10	10	



**DOPPIA
MAPPA**

SERRATURE PER PORTE BASCULANTI A DOPPIA MAPPA A 5 GORGE

DOUBLE BIT LOCKS FOR OVERHEAD GARAGE DOORS - 5 GORGES

SERRURES POUR PORTES BASCULANTES À DOUBLE PANNETTON - 5 GORGES

CERRADURAS DE GORJAS PARA PUERTAS BASCULANTES - 5 GORJES



Gorge guidate dalle gole presenti sugli speciali perni a pettine
 Supergorge anti effrazione
 Molla antiusura della chiave
 5 zone laterali sulla chiave per la movimentazione dei catenacci
 Apertura interna ed esterna con leva di sblocco

Gorges guided by the traks present on the special pins
 Supergorges anti burglary
 Anti-usure spring of the key
 5 lateral zones on the key for the movement of the bolts
 Internal and external opening by release cam

Gorge guidée par les gorges présentes sur les speciaux pens
 Supergorge anti cambriolage
 Ressort d'usure de clé
 5 zones latérales sur la clé pour le mouvement des pènes
 Ouverture interne et externe par la levier de déverrouillage

Gorjias guiado por las pistas presentes en los pasaderos especiales
 Supergorjas antirrobo
 Muelle antidesgaste de la llave
 5 zonas laterales en la llave para el movimiento de los cerrojos
 Apertura interna y externa por la leva de desbloqueo

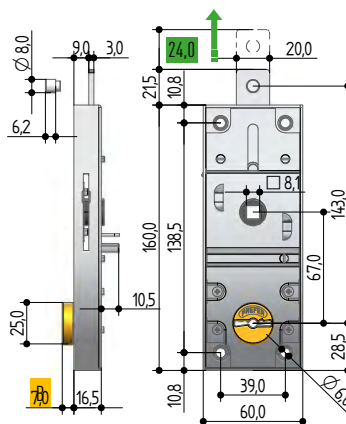

8651

codice code código														B mm		②			MIN ORD
1	2	3	4	5	6	7	8	9	10	11	12	13	14						
8	6	5	1	•	0	8	1	0	•	0	2	0	0	7	7703.0500	40	1	10	
8	6	5	1	•	0	8	1	2	•	0	2	0	0	14	7703.0500	40	1	1	
8	6	5	1	•	0	8	1	4	•	0	2	0	0	19	7703.0500	40	1	1	
8	6	5	1	•	0	8	1	6	•	0	2	0	0	24	7703.0501	40	1	1	
8	6	5	1	•	0	8	1	8	•	0	2	0	0	27	7703.0501	40	1	1	
8	6	5	1	•	0	8	1	A	•	0	2	0	0	34	7703.0501	40	1	1	
8	6	5	1	•	0	8	1	C	•	0	2	0	0	42	7703.0501	40	1	1	



SPRANGA

SOLUZIONI DI SICUREZZA
 SECURITY SOLUTIONS
 SOLUTIONS DE SÉCURITÉ
 SOLUCIONES DE SEGURIDAD

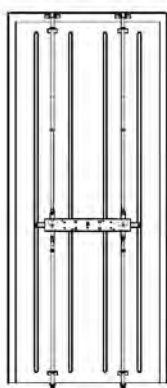
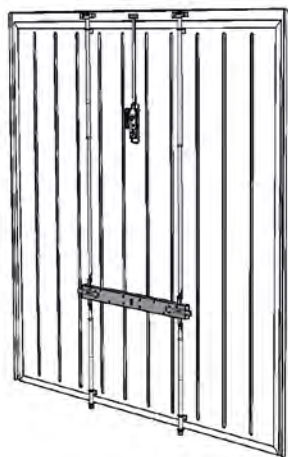

Z Senza cilindro
 Without cylinder
 Sans cylindre
 Sin cilindro

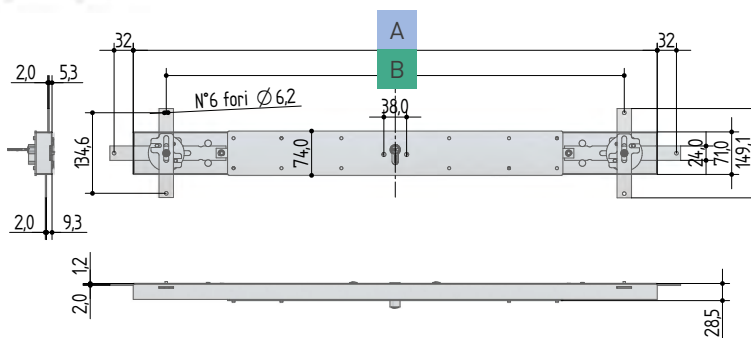

BSP3

codice code código														A	B			MIN ORD
1	2	3	4	5	6	7	8	9	10	11	12	13	14	mm	mm			
B	S	P	3	•	0	0	1	Z	•	0	0	0	0	875	765	-	1	1
B	S	P	3	•	0	1	1	Z	•	0	0	0	0	500	410	-	1	1

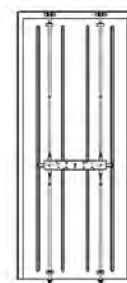
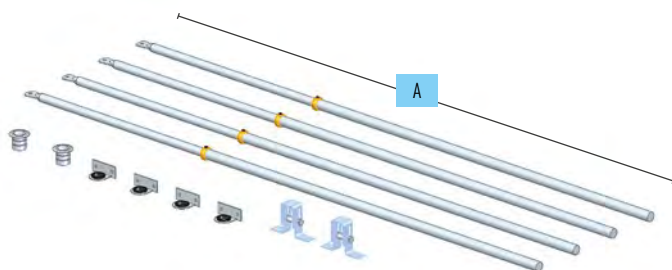

BSK1

codice code código														A			MIN ORD
1	2	3	4	5	6	7	8	9	10	11	12	13	14	mm			
B	S	K	1	•	0	0	0	0	•	0	0	0	0	720:1320	-	1	1



KIT SICUREZZA

SERRATURE PER PORTE BASCULANTI
LOCKS FOR OVERHEAD GARAGE DOORS
SERRURES POUR PORTES DE GARAGE BASCULANTES
CERRADURAS PARA PUERTA DE GARAJE SUPERIOR

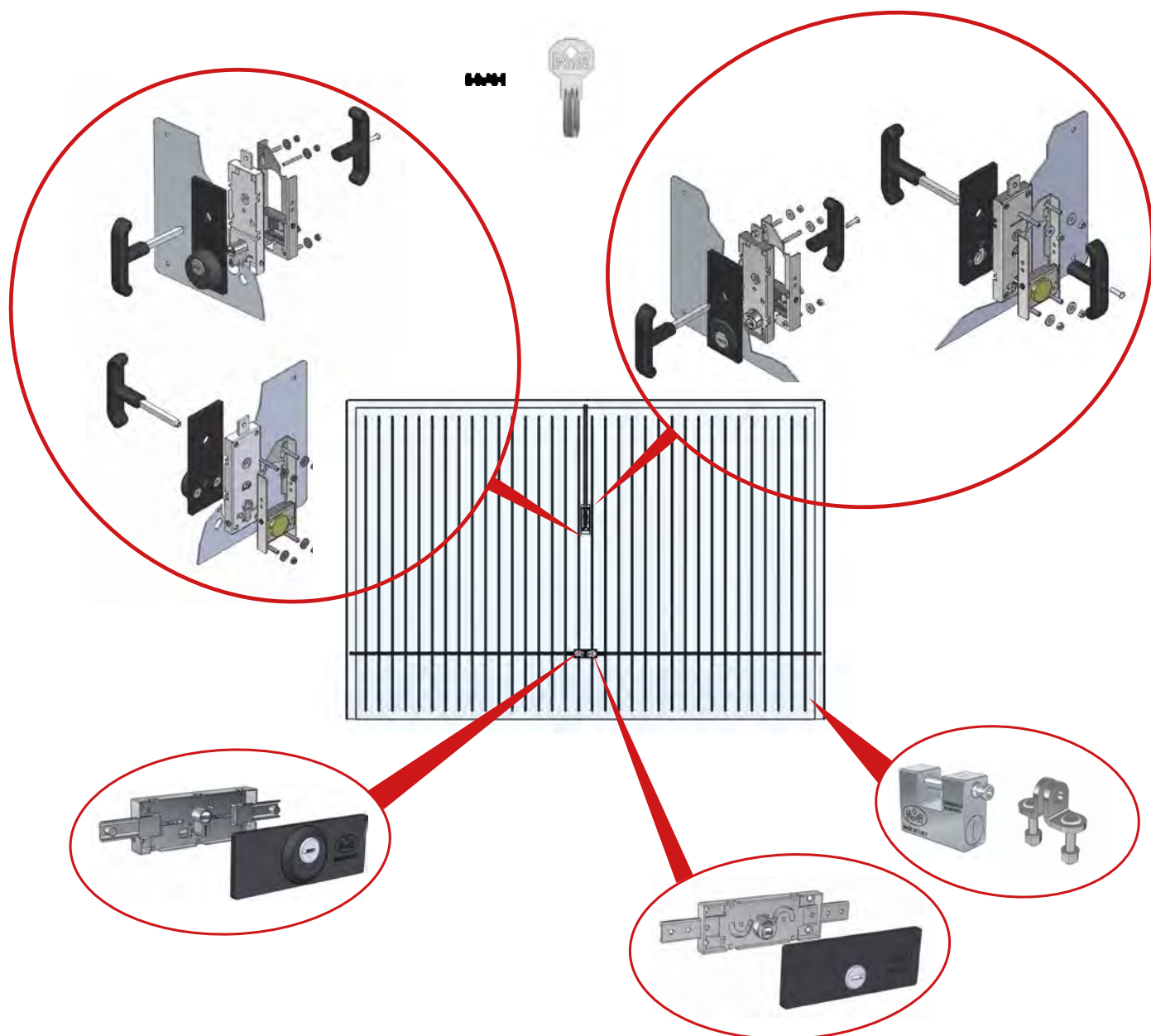

 **CALL US**



KIT SICUREZZA CILINDRO TONDO

DISPOSITIVI DI SICUREZZA PER SERRATURE A CILINDRO TONDO

SECURITY KIT FOR GARAGE DOORS

KIT DE SÉCURITÉ POUR PORTES DE GARAGE

KIT DE SEGURIDAD PARA PUERTAS DE GARAJE

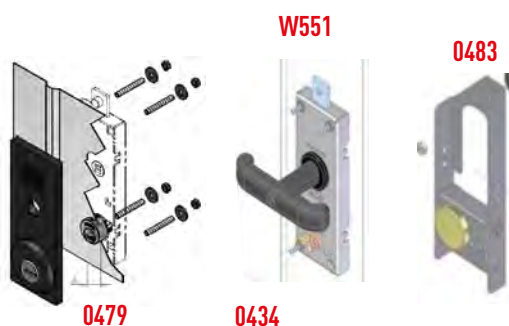

$$\mathbf{KBT1.0000.0000} = W51.0822.0000 + 0479.0034.W000 + 0434.0800.0000 + 0483.0000.0000$$

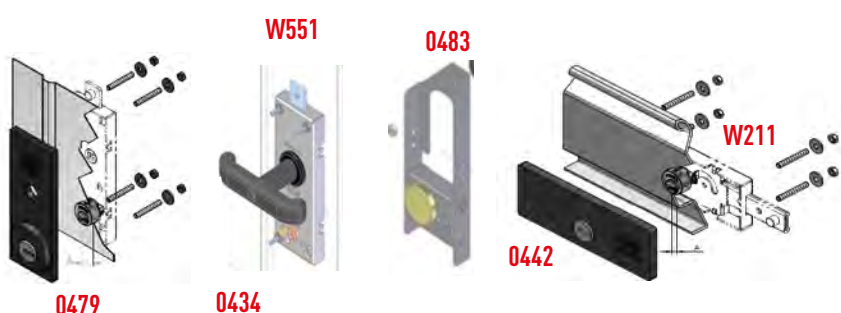

$$\mathbf{KBT2.SER1.0000} = W51.0822.0000 + W211.0020.0000 + 0479.0034.W000 + 0483.0000.0000 + 0434.0800.0000 + 0442.0030.W000$$

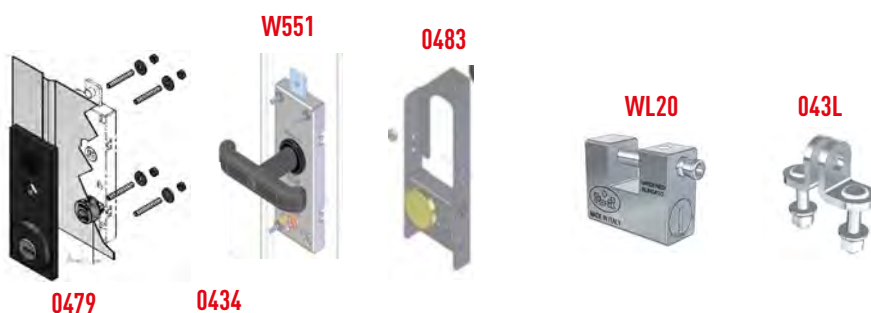

$$\mathbf{KBT2.LUC1.0000} = W51.0822.0000 + 0479.0034.0000 + 0483.0000.0000 + 0434.0800.0000 + WL20.0000.0000 + 043L.0110.0000$$

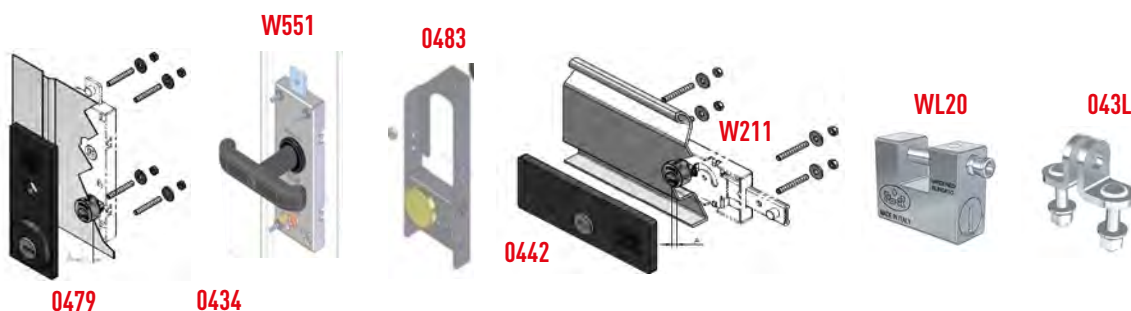

$$\mathbf{KBT3.SER1.LUC1} = W51.0822.0000 + W211.0020.0000 + 0479.0034.0000 + 0483.0000.0000 + 0434.0800.0000 + 0442.0030.W000 + WL20.0000.0000 + 043L.0110.0000$$



KIT SICUREZZA CILINDRO A PROFILO

DISPOSITIVI DI SICUREZZA PER SERRATURE A CILINDRO A PROFILO INT.70

SECURITY KIT FOR GARAGE DOORS

KIT DE SÉCURITÉ POUR PORTES DE GARAGE

KIT DE SEGURIDAD PARA PUERTAS DE GARAJE



A = 70mm

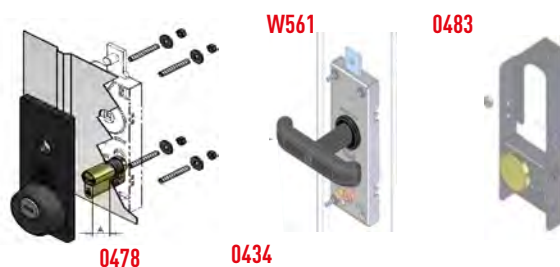

$$\text{KBP1.0000.0000} = 0478.0030.W000 + W561.0820.0000 + 0434.0800.0000 + 0483.0000.0000$$

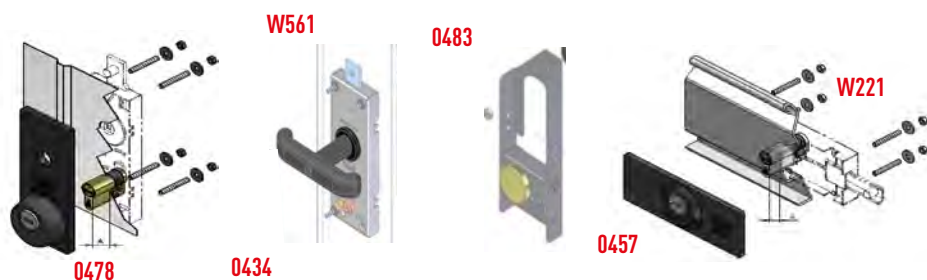

$$\text{KBP2.SER2.0000} = 0478.0030.W000 + W561.0820.0000 + 0434.0800.0000 + 0483.0000.0000 + 0457.0031.W000 + W221.0020.0500$$

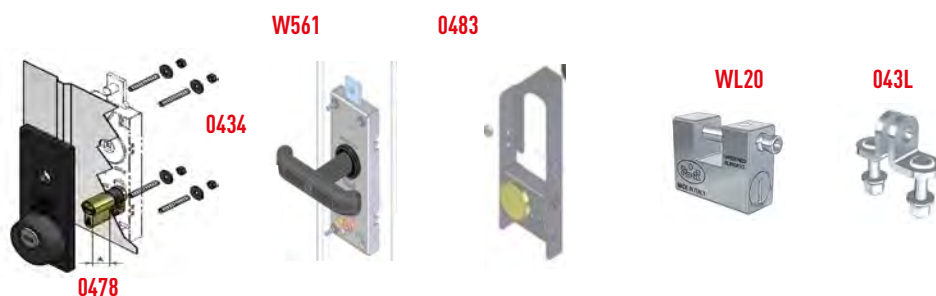

$$\text{KBP2.LUC1.0000} = 0478.0030.W000 + W561.0820.0000 + 0434.0800.0000 + 0483.0000.0000 + WL20.0000.0000 + 043L.0110.0000$$

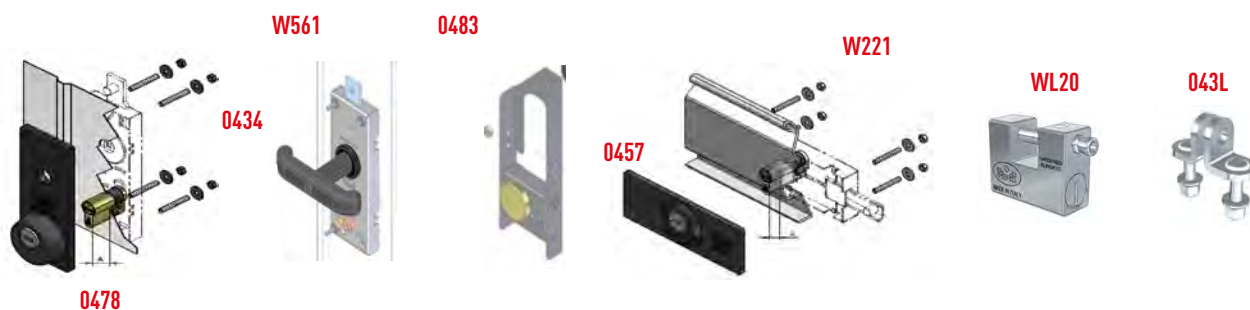

$$\text{KBP3.SER2.LUC1} = 0478.0030.W000 + W561.0820.0000 + 0434.0800.0000 + 0483.0000.0000 + 0457.0031.W000 + W221.0020.0500 + WL20.0000.0000 + 043L.0110.0000$$

Rivolgersi al ns ufficio commerciale per le misure del cilindro desiderate

Contact our sales office for the desired euro profile cylinder sizes

Contacter notre service commercial pour les dimensions de cylindre souhaitées

Póngase en contacto con nuestro departamento comercial para las medidas del cilindro que desee



KW574

KIT DI SICUREZZA PER PORTE BASCULANTI

SECURITY KIT FOR GARAGE DOORS

KIT DE SÉCURITÉ POUR PORTES DE GARAGE

KIT DE SEGURIDAD PARA PUERTAS DE GARAJE



A=70mm

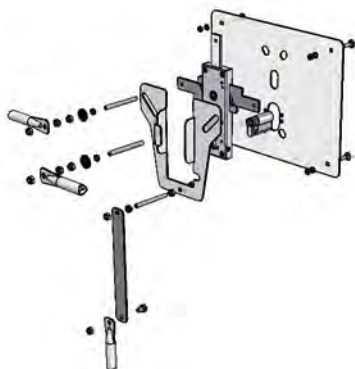

KW574 = W574.0820.0001 + 0469.0010.0000 + 0470.0010.0000 + BSK2.0000.0200

codice code código																			
1	2	3	4	5	6	7	8	9	10	11	12	13	14						
K	W	5	7	4	•	6	8	2	0	•	0	0	0	WE05.2410	7300.2A00	-	1	1	

OPTIONAL

+
Maniglie
Handles
0434 - 0456 - 0433 - 0478



0470

codice code código																
1	2	3	4	5	6	7	8	9	10	11	12	13	14			
0	4	7	0	•	0	0	1	0	•	0	0	0	0	-	1	1



BSK2

codice code código														A mm			
1	2	3	4	5	6	7	8	9	10	11	12	13	14				
B	S	K	2	•	0	0	0	0	•	0	0	0	0	720:1320	-	1	1

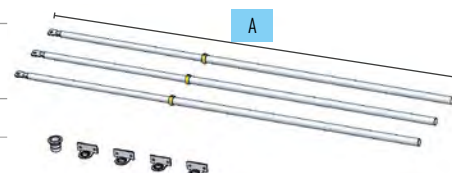



KIT

KIT DI SICUREZZA PER PORTE BASCULANTI - DOPPIA MAPPA

SECURITY KIT FOR GARAGE DOORS - DOUBLE BIT

KIT DE SÉCURITÉ POUR PORTES DE GARAGE - DOUBLE PANNETTON

KIT DE SEGURIDAD PARA PUERTAS DE GARAJE- DE GORJAS

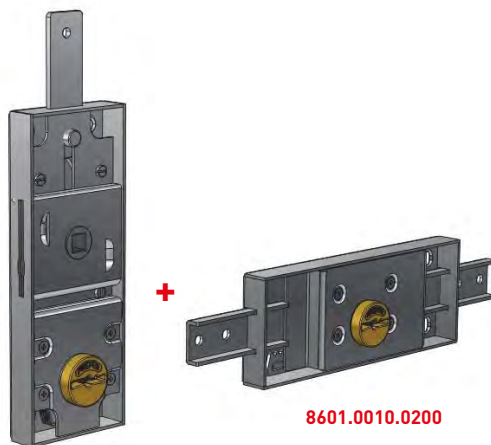

8651.0810.0200

8601.0010.0200

0713
CALLUS

codice code código														B	MIN		ORD
1	2	3	4	5	6	7	8	9	10	11	12	13	14	mm			
0	7	1	3	•	0	8	1	0	•	0	7	0	0	7			1

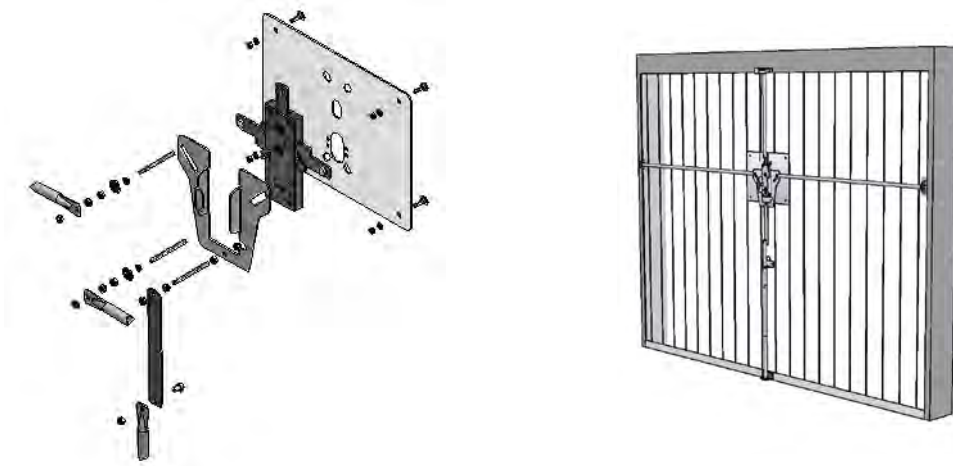

K8653 = 8653.6814.0200 + 0469.0010.000 + 0470.0010.0000 +BSK2.0000.0000

codice code código															B	MIN		ORD
1	2	3	4	5	6	7	8	9	10	11	12	13	14	15	mm			
K	8	6	5	3	•	6	8	1	4	•	0	2	0	0	19			1

OPTIONAL

+

Maniglie
Handles
0434 - 0456 - 0432





ACCESSORI

PLACCHE ESTERNE ANTIEFFRAZIONE

SECURITY MOUNTING PLATES

PLAQUES DE FIXATION

PLACAS DE FIJACION

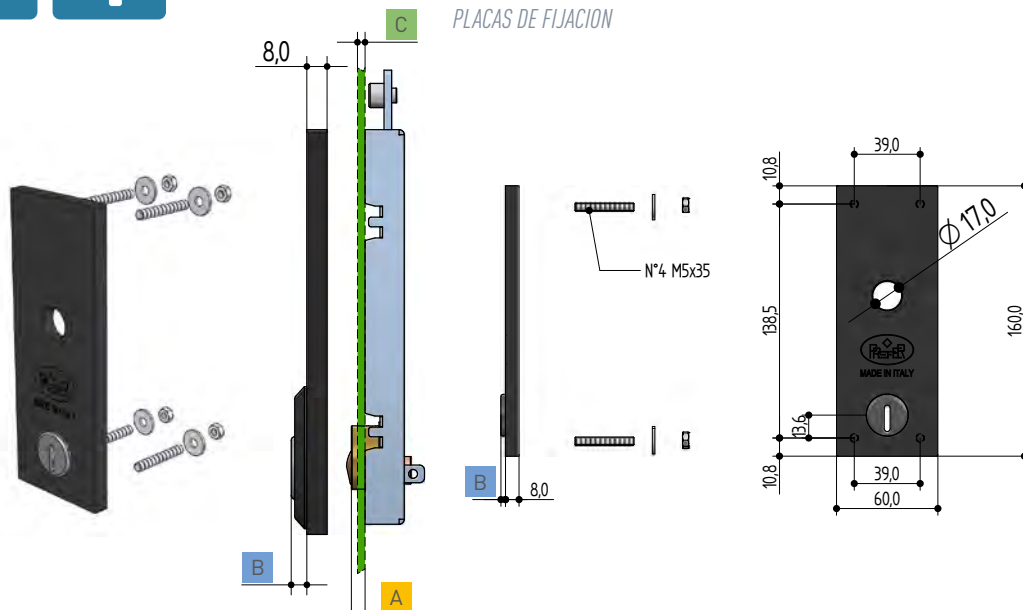

0479

codice code código														A	B	C	per articolo for code
1	2	3	4	5	6	7	8	9	10	11	12	13	14	mm	mm	mm	
0	4	7	9	•	0	0	3	0	•	W	0	0	0	5,5	2,7	0,6	B551.0810.0200
0	4	7	9	•	0	0	3	0	•	W	0	0	0	5,5	2,7	0,6 : 7	W551.0820.0200
0	4	7	9	•	0	0	3	2	•	W	0	0	0	9	4,8	0,6	B551.0812.0200
0	4	7	9	•	0	0	3	2	•	W	0	0	0	5,5	4,8	0,6 : 7	W551.0820.0200
0	4	7	9	•	0	0	3	3	•	W	0	0	0	9	2,8	0,6	B551.0812.0200
0	4	7	9	•	0	0	3	3	•	W	0	0	0	9	2,8	0,6 : 10	W551.0822.0200
0	4	7	9	•	0	0	3	4	•	W	0	0	0	12,5	8,3	0,6	B551.0814.0200
0	4	7	9	•	0	0	3	4	•	W	0	0	0	9	8,3	0,6 : 4	W551.0822.0200
0	4	7	9	•	0	0	3	5	•	W	0	0	0	12,5	6,3	0,6	B551.0814.0200
0	4	7	9	•	0	0	3	5	•	W	0	0	0	9	6,3	0,6 : 10	W551.0822.0200

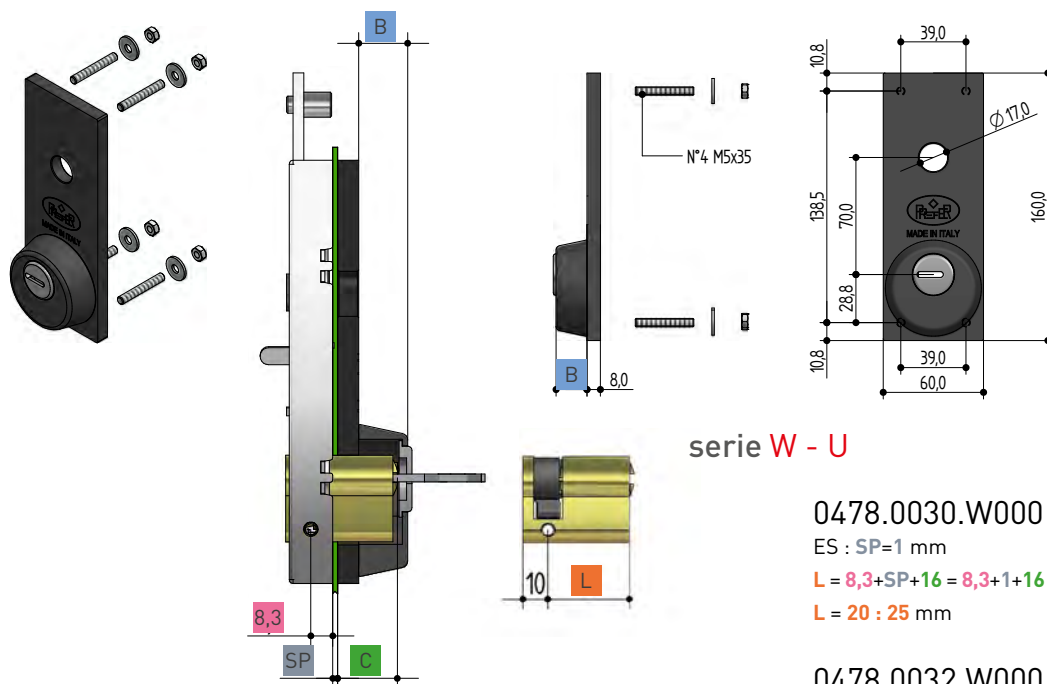

A = 70mm

serie W - U

0478.0030.W000

ES : SP=1 mm

L = 8,3+SP+16 = 8,3+1+16 = 25,3 mm (range-5 mm)

L = 20 : 25 mm

0478.0032.W000

ES : SP=1 mm

L = 8,3+SP+22 = 8,3+1+22 = 31,3 mm (range-5 mm)

L = 26 : 31 mm

0478

codice code código														B	C
1	2	3	4	5	6	7	8	9	10	11	12	13	14	mm	mm
0	4	7	8	•	0	0	3	0	•	W	0	0	0	12	16
0	4	7	8	•	0	0	3	2	•	W	0	0	0	18,5	22



DISPOSITIVI DI PROTEZIONE - SICUREZZA

SECURITY MOUNTING PLATES

PLAQUES DE FIXATION

PLACAS DE FIJACION

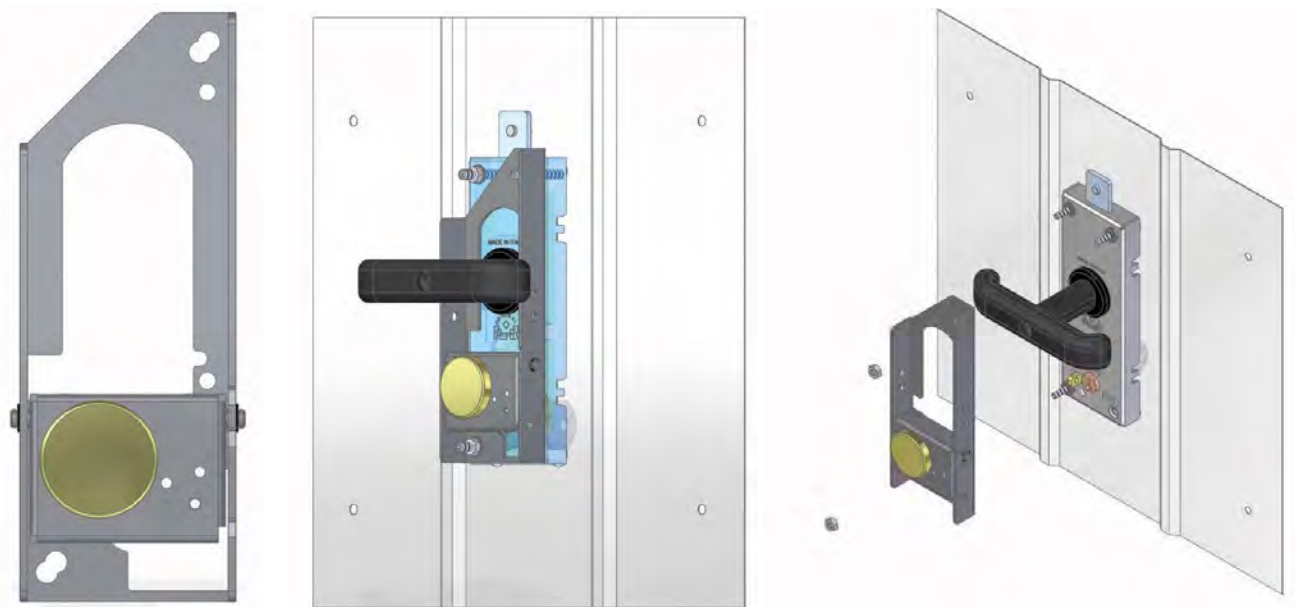

0483

codice code código														per articolo for code
1	2	3	4	5	6	7	8	9	10	11	12	13	14	
0	4	8	3	•	0	0	0	0	•	0	0	0	0	B551 - B561
0	4	8	3	•	1	0	0	0	•	0	0	0	0	6574 - 6562
0	4	8	3	•	2	0	0	0	•	0	0	0	0	6564 - 6565 - 6566 6567 - 6568 - 6569

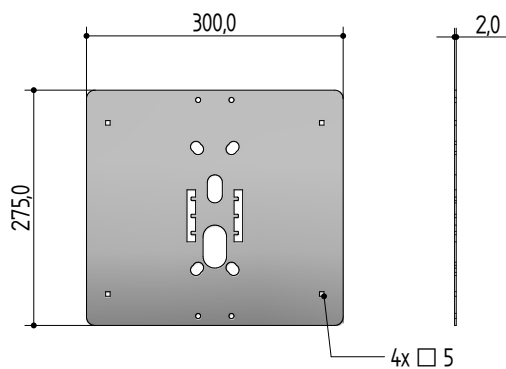

0469

codice code código																MIN ORD
1	2	3	4	5	6	7	8	9	10	11	12	13	14			
0	4	6	9	•	0	0	1	0	•	0	0	0	0	-	1	1



CAVALLOTTI
MOUNTING U-BOLTS
 PLAQUES DE FIXATION
 PLACAS DE FIJACION

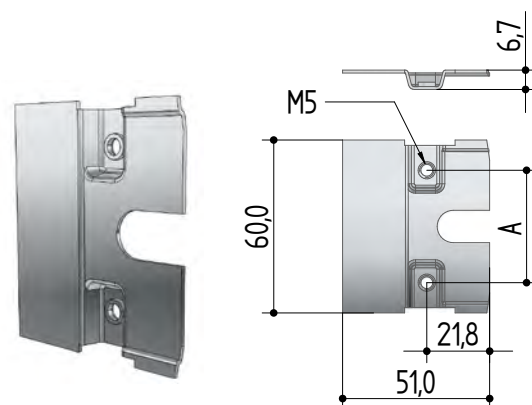

0458

codice code código														A mm	per articolo for code
1	2	3	4	5	6	7	8	9	10	11	12	13	14	39	6593-6594-6598-6599- 8601-8632-8633
0	4	5	8	•	E	0	0	0	•	0	0	0	0	44	6591-6591-6596-6597

Completo di viti
With screws

W

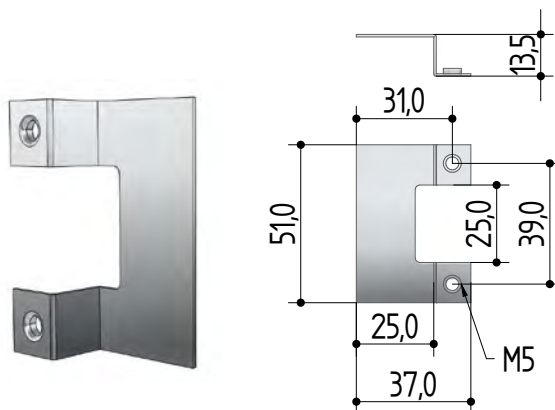

0459

codice code código														A mm	per articolo for code
1	2	3	4	5	6	7	8	9	10	11	12	13	14	39	B511-B551-B561-6562-6563- 6574-B561-6584-B5A1-S511 -S551-S551-S561-S562- S563-S574-S581-S584-S5A1

Completo di viti
With screws

W



MANIGLIE E PLACCHE

HANDLES AND PLATES

POIGNÉES ET PLAQUES

MANEJAS Y PLACAS

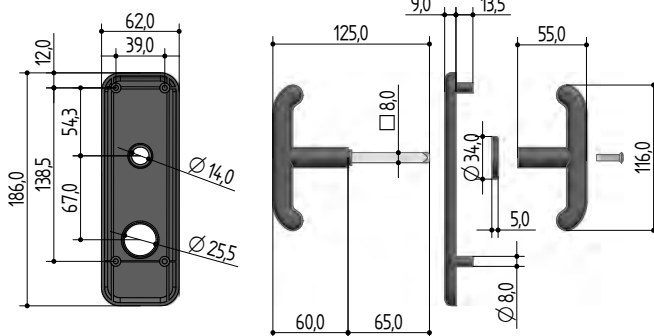

+ Quadro maniglia / Handle hole
Carré de poignée / Perno cuadrado

8	8 x 8 mm
7	7 x 7 mm
9	9 x 9 mm

codice code código														spessore porta door thickness épaisseur de la porte espesor de la puerta	per articolo - for code par code - por código			MIN ORD	
0432	1	2	3	4	5	6	7	8	9	10	11	12	13	14	0,5 : 1	B551-8651-8652-8653-W551			10
	0	4	3	2	•	0	8	0	0	•	0	0	0	0			50	1	

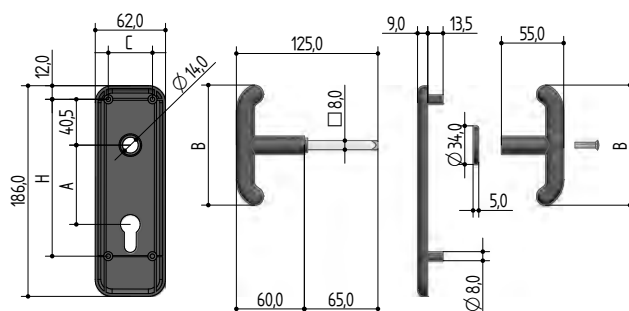
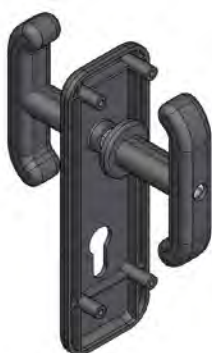

codice code código														spessore porta door thickness épaisseur de la porte espesor de la puerta	A	B	C	H	per articolo - for code par code - por código			MIN ORD	
0433	1	2	3	4	5	6	7	8	9	10	11	12	13	14	0,5 : 1	60	106	44	144	INT. 60			10
	0	4	3	3	•	0	8	0	0	•	0	0	0	0						INT. 70 (NO 6599)	50	1	10
	0	4	3	3	•	E	8	0	0	•	0	0	0	0							50	1	10

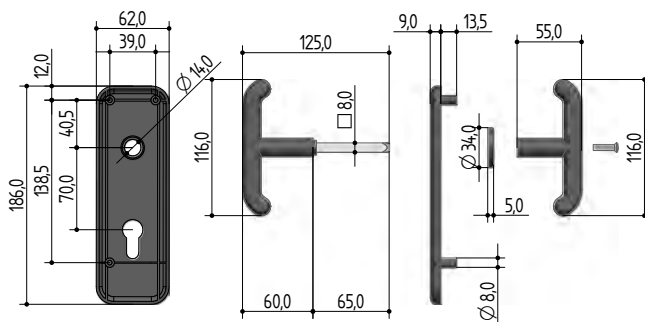

codice code código														spessore porta door thickness épaisseur de la porte espesor de la puerta	per articolo - for code par code - por código			MIN ORD	
0436	1	2	3	4	5	6	7	8	9	10	11	12	13	14	0,5 : 1	6599-W599			10
	0	4	3	6	•	E	8	0	0	•	0	0	0	0			50	1	



MANIGLIE
HANDLES
POIGNÉES
MANEJAS

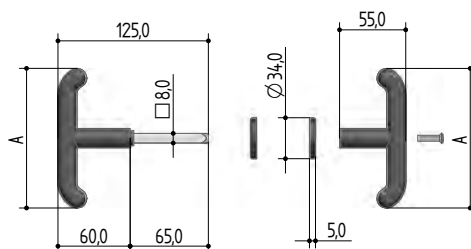

+		Quadro maniglia / Handle hole Carré de poignée / Perno cuadrado
8	8 x 8 mm	
7	7 x 7 mm	
9	9 x 9 mm	

0434	codice code código														per articolo - for code par code - por código			MIN ORD
	1	2	3	4	5	6	7	8	9	10	11	12	13	14				
	0	4	3	4	•	0	8	0	0	•	0	0	0	0				

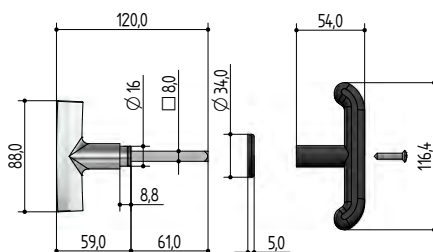

0456	codice code código														per articolo - for code par code - por código			MIN ORD
	1	2	3	4	5	6	7	8	9	10	11	12	13	14				
	0	4	5	6	•	0	8	0	0	•	0	0	0	0				



0435	codice code código														per articolo - for code par code - por código			MIN ORD
	1	2	3	4	5	6	7	8	9	10	11	12	13	14				
	0	4	3	5	•	0	8	0	0	•	0	0	0	0				