



SG2X

SISTEMA MECCANICO A RIARMO AUTOMATICO SINCRONIZZATO PER PORTE MOTORIZZATE

MECHANICAL SYNCHRONIZED AUTOMATIC CLOSING SYSTEM FOR MOTORIZED DOORS

SYSTÈME MÉCANIQUE À RÉARMEMENT AUTOMATIQUE SYNCHRONISÉ POUR PORTES MOTORISÉES

SISTEMA MECÁNICO DE REARME AUTOMÁTICO SINCRONIZADO PARA PUERTAS MOTORIZADAS



SG20



SG21

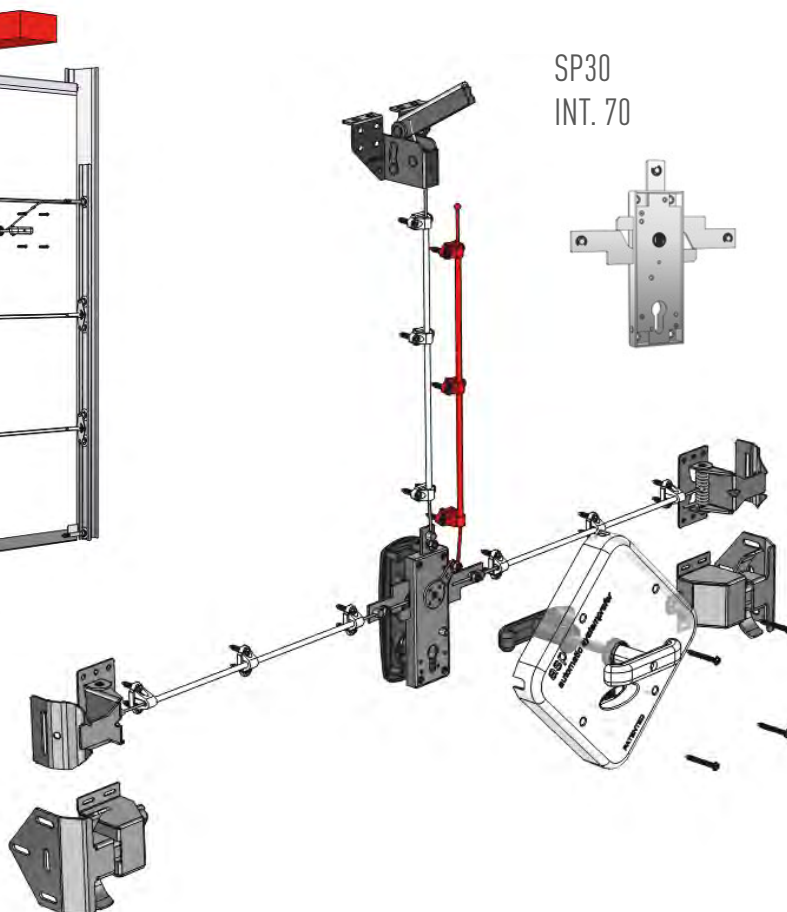
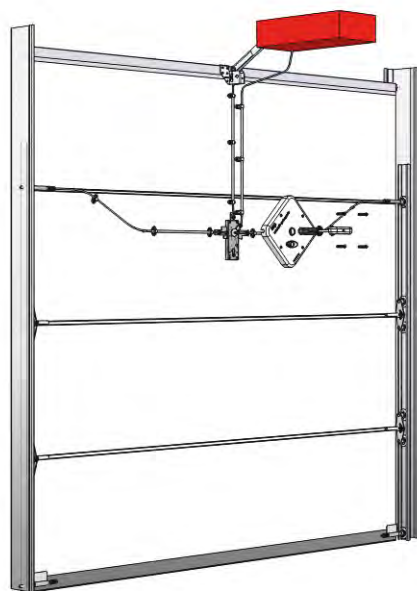



SG2X

SISTEMA MECCANICO A RIARMO AUTOMATICO SINCRONIZZATO PER PORTE MOTORIZZATE

MECHANICAL SYNCHRONIZED AUTOMATIC CLOSING SYSTEM FOR MOTORIZED DOORS

SYSTÈME MÉCANIQUE À RÉARMEMENT AUTOMATIQUE SYNCHRONISÉ POUR PORTES MOTORISÉES

SISTEMA MECÁNICO DE REARME AUTOMÁTICO SINCRONIZADO PARA PUERTAS MOTORIZADAS

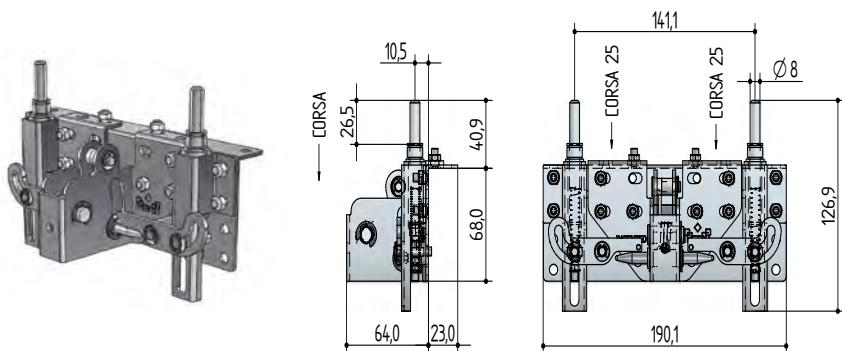

codice | code | código

SG20

1	2	3	4	5	6	7	8	9	10	11	12	13	14
S	G	2	0	•	Z	0	1	0	•	0	0	0	0

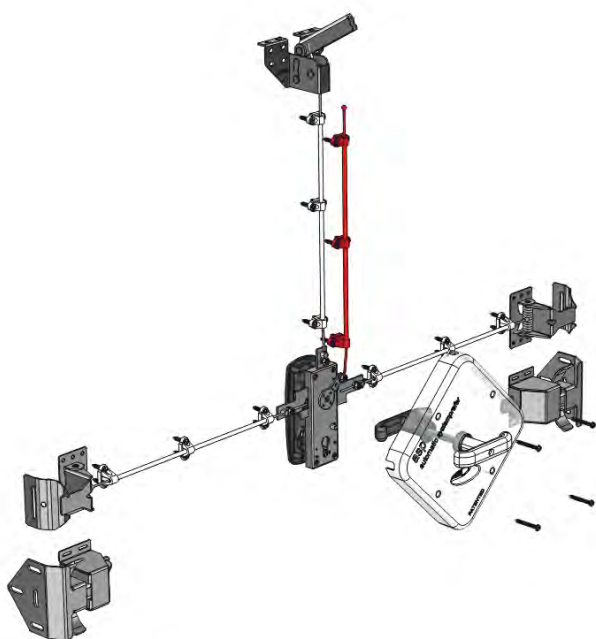

codice | code | código

SG21

1	2	3	4	5	6	7	8	9	10	11	12	13	14
S	G	2	1	•	0	0	0	Z	•	1	0	0	0

+

latch

- 0 SP13
- 1 SP14

+

placca / cover
couverture / tapa

- Z no cover SP60
- 0 SP60+0433
- 1 SP60+0434
- 2 SP60+0445

+

lung. cavo/cable length
longueur du câble/longitud
del cable

- 1 1,8 m
- 2 3,0 m

Z

Senza cilindro
Without cylinder
Sans cylindre
Sin cilindro

+

cavo sblocco / motor cable cable
motor / cable motor

- Z no
- 1 1800 mm
- 2 3000 mm